

ROADS AND BUILDINGS DEPARTMENT
GOVERNMENT OF GUJARAT

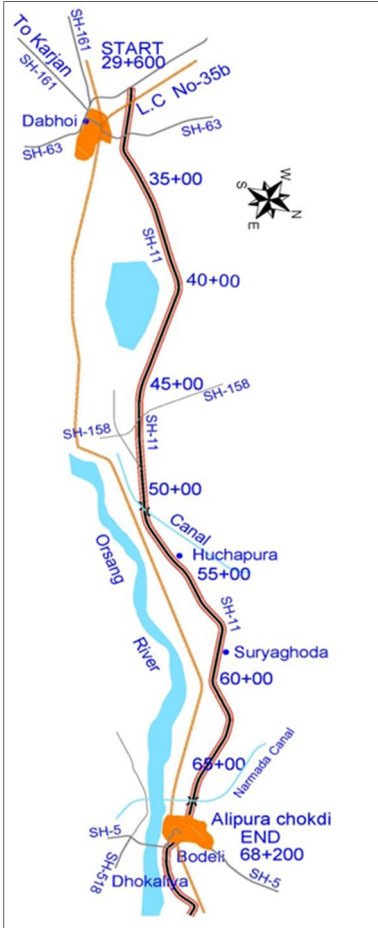

**Project Preparatory Works Consultancy Services for
Gujarat State Highway Project - II**



**Volume-IV:
Environmental Management Plan (EMP)
(DABHOI – BODELI)**



May 2013



VOLUME-IV

ENVIRONMENTAL MANAGEMENT PLAN

CONTENTS

1.	INTRODUCTION.....	1
1.1	BACKGROUND.....	1
1.2	CONTEXT FOR THE EMP	1
1.3	BRIEF DESCRIPTION OF THE PROJECT ROAD	1
1.4	CLEARANCE REQUIREMENTS	2
1.5	STRUCTURE OF THE REPORT.....	4
2.	ENVIRONMENTAL ISSUES	5
2.1	SUMMARY OF IMPACTS.....	5
2.2	SPECIFIC MEASURES	6
2.3	ENHANCEMENT MEASURES	9
3.	ENVIRONMENTAL MANAGEMENT PLAN.....	11
3.1	PRE-CONSTRUCTION STAGE.....	11
3.2	CONSTRUCTION STAGE.....	11
3.3	OPERATION STAGE.....	12
4.	IMPLEMENTATION ARRANGEMENTS	26
4.1	ENVIRONMENTAL MONITORING PLAN	26
4.2	REPORTING SYSTEM	29
4.3	CLAUSE FOR NONCONFIRMITY TO EMP-PROTECTION OF THE ENV.	30
4.4	INSTITUTIONAL SETUP	30
4.5	GOOD ENVIRONMENTAL CONSTRUCTION GUIDELINES	31
5.	ENVIRONMENTAL MANAGEMENT BUDGET.....	33

List of Tables

Table 1.1: List of GSHP-II DPR Corridors	1
Table 1.2: Applicable Laws and Regulations	3
Table 2.1: Summary of Environmental Impacts and Design Measures	5
Table 2.2: Environmental and Social Specific Measures	6
Table 2.3: Selected Enhancement Measures for Proposed Project corridor	10
Table 3.1: Environmental Management Plan	13
Table 4.1: Environmental Monitoring Indicators	26
Table 4.2: Environmental Monitoring Plan	28
Table 4.3: Summary details of Reporting	29
Table 4.4: Institutional Responsibilities.....	31
Table 4.5: Guideline for Good Environmental Practices.....	31
Table 5.1: Budgetary Provisions for Environmental Management Measures.....	33

List of Figures

Figure 1.1: SH - 11Dabhoi-Bodeli Corridor key Map (Existing Chainage).....	2
Figure 2.1: Junction Improvement atCh29+600	6
Figure 2.2: Junction Design at Ch 46+725	7

List of Appendices

Appendix 1: Environmental Reporting System
Appendix 2: Environmental Monitoring Location
Appendix 3: Enhancement Drawings
Appendix 4: Guidelines for Environmental Management
Appendix 5: Bill of Quantities (BoQ)

List of Abbreviations

BOQ	Bill of Quantity
EIA	Environmental Impact Assessment
EMP	Environmental Management Plan
CoI	Corridor of Impact
CO	Carbon monoxide
CPR's	Common Property Resources
GPCB	Gujarat Pollution Control Board
GSHP-II	Gujarat State Highways Project – II
GoG	Government of Gujarat
LASA	LEA Associates South Asia Pvt. Ltd.
LHS	Left Hand Side
MoRTH	Ministry of Road Transport and Highways
NOC	No Objection Certificate
NO _x	Nitrates of Oxygen
NH ₃	Ammonia
NGO	Non-Government Organisation
PIU	Project Implementation Unit
Pb	Lead
O ₃	Ozone
R&BD	Roads and Buildings Department
RPF	Resettlement Policy Framework
RoW	Right of Way
RAP	Resettlement Action Plan
RPM	Respiratory Particle Matter
RHS	Right Hand Side
SC	Supervision consultant
SO ₂	Sulfur di oxide
SPM	Suspended Particle Matter

1. INTRODUCTION

1.1 BACKGROUND

1. The Roads and Buildings Department (R&BD), Government of Gujarat (GoG) has taken up the preparation of the second Gujarat State Highway Project (GSHP-II), covering up-gradation, maintenance and improvement of identified core road network for loan appraisal with the World Bank. Towards project preparation, R&BD has retained M/s LEA Associates South Asia Pvt. Ltd. (LASA) as Project Preparatory Works Consultants to prepare plans for the widening and up gradation of highways as well as for carrying out the assessment of environmental and social impacts. As a pre-requisite for loan appraisal, the World Bank, R&BD-GoG has selected nine corridors at this stage, for preparation of detailed designs. The details of the selected corridors are given in Table 1.1.

Table 1.1: List of GSHP-II DPR Corridors

Sr. No.	Work Type	Link Name	Corridor No	Length km
1.	Two Laning / Wide Two Laning	Dabhoi – Bodeli	SH-11	38.60
2.		Dhanduka – Dholera	SH-20	27.00
3.		Atkot-Gondal	SH-01	35.55
4.	Four laning	Mehsana – Himatnagar	SH-55	66.15
5.	Two Laning / Wide Two Laning	Umreth- Vasad (including Kapadvanj-Ladvel)	SH-83,SH-188, SH151	35.45
6.		Bayad – Lunawada	SH-69,SH-63	44.56
7.		Dhansura – Meghraj	SH-145, SH-146	46.65
8.		Lunawada – Khedapa	SH-02, SH-152	56.70
9.	Rehabilitation/ maintenance	Paliyad-Dhanduka	SH-01	46.00

Source: R&BD

1.2 CONTEXT FOR THE EMP

2. As part of the project preparation, an Environmental Impact Assessment (EIA) has been undertaken for the proposed roads. This EMP for the Dabhoi-Bodeli (SH-11) corridor is based on the findings of EIA carried out in the project corridor, and provides the necessary details for the effective implementation of the environmental management measures required for addressing the potential environmental impacts in the project. This Environmental Management Plan assists the project proponent and the contractor to implement the environmental management measures.

1.3 BRIEF DESCRIPTION OF THE PROJECT ROAD

3. The project corridor (SH-11) starts at Dabhoi (km 29+600) and ends at Bodeli (km 68+200). The total length of the corridor is 38.6km (Figure 1.1). The project corridor traverses through plain terrain and it is characterized by siltyclay soil. The present road configuration is two lane with hard shoulder with an average carriage way width of 7.0m

and the proposed configuration is two lane with paved shoulder and hard shoulder. The available RoW is 30m and the pavement status of the entire corridor is in fair-poor condition.

4. The project corridor passes through Dabhoi and Sankhedataluka of Vadodara district, comprising of 27 villages and a town (Bodeli). Major settlements along the corridor are Vega village, Simaliya village, Targol village and Bodeli town.

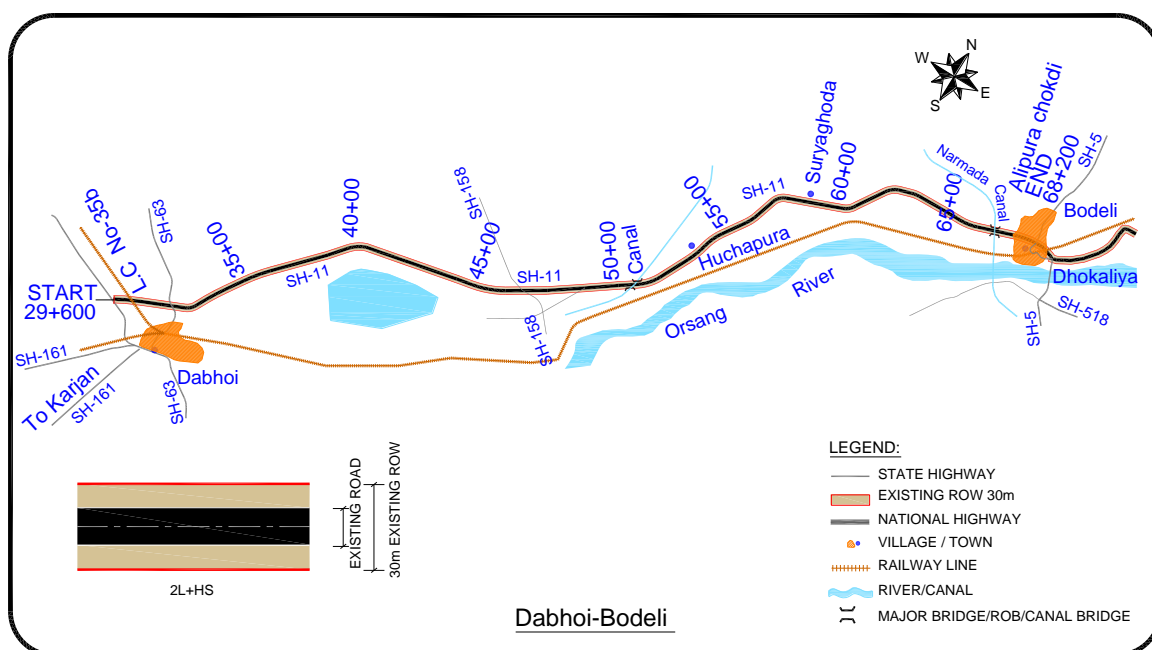

Figure 1.1: SH - 11 Dabhoi-Bodeli Corridor key Map (Existing Chainage)

1.4 CLEARANCE REQUIREMENTS

5. **Environmental Clearance:** As per the new amendment of EIA notification 2006, dated 4th April, 2011 environmental clearance has been made mandatory only for new state highways. Hence, the widening / strengthening and improvement works on existing State Highways are not covered under the ambit of the notification and are not categorized either as Category ‘A’ or Category ‘B’. However, the project shall require obtaining consent from competent authorities such as the Gujarat Pollution Control Board (GPCB), for the purpose of obtaining a ‘*Consent to Establish*’ an online Common Application (as per Schedule-I) needs to be submitted, under Water (Prevention and Control of Pollution) Act, 1974, Air (Prevention and Control of Pollution) Act, 1981) and authorization under Hazardous Wastes (Management and Handling) Rules, 1989, as amended.

6. **Forest Clearance:** As per the Gujarat Government Gazette dated 16th August, 1973, Dabhoi-Bodeli (SH-11) is declared as, Notified Protected Forest, under Forest (Conservation) Act 1980. Hence, any infrastructure development in the project corridor, including strengthening and widening activity necessitates forest clearance.

7. As per the directions of the forest department, the corridors which had been declared as State Highways before 1980 will have 9.75m (Black Top and Shoulder) as road way width; beyond this any requirement, forest land diversion proposal shall be submitted. Adopting this

criterion, the project corridor Dabhoi-Bodeli (SH-11) has been declared as State Highways before 1980. Hence, the width of 9.75m is considered as basis for applying forest clearance beyond this width.

8. The proposed widening and strengthening is planned to be executed in 16m proposed width and estimated to be 24.12ha¹. As per the Forest Act 1980, Form 'A' (for the diversion of the forest land) had been filled and submitted along with the necessary enclosures to the District Forest Officer (DFO) through State Road Project (SRP) Division, Vadodara for further action.

9. After that consultation with the client towards saving of trees/green tunnel, the CoI approach has been designed such as; a 12m CoI approach has been adopted at stretches having green tunnels, 16m CoI has been adopted for stretches which includes rural and urban sections and those which do not contain green tunnels and 18m CoI has been adopted at the junctions for improvement. With this approach, it is estimated by the forest department that 4346 trees have been saved when compared to forest department tree counts for overall 16m CoI.

10. **Other Clearances:** Implementation of the project works would require clearances from several other line agencies. These would have to be obtained by the contractor before commencement of civil works in the project area. The clearances that are to be obtained are presented in Table 1.2.

Table 1.2: Applicable Laws and Regulations

Sr. No.	Clearances	Acts	Approving Agency	Applicability to the Project	² Indicative Time Frame	Responsibility	
						Execution	Supervision
PROJECT PREPARATION STAGE							
1	No Objection Certificate (NOC)	Water (Prevention and Control of Pollution) Act 1974, Air (Prevention and Control of Pollution) Act 1981	Gujarat Pollution Control Board	Applicable	3-6 months	PIU	-
2	Diversion of forest land for Non-forest use	Forest Conservation Act (1980) Forest Conservation Rules (2003) and Guidelines issued to date	Regional Office Western Zone, MoEF, Bhopal	Applicable	9-12 months	PIU	-
3	Permission for removal of avenue tree within the PROW	Forest Conservation Act (1980) Forest Conservation Rules (2003) and Guidelines issued to date	Forest Department, GoG	Applicable	3 -6 month for each workout area	PIU	-
PROJECT IMPLEMENTATION STAGE							
4	Permission for Withdrawal of Surface Water from Rivers, Nala, Water harvesting structure/ Reservoirs/ Ponds/ Irrigation canals	Gujarat Water Supply and Sewerage Board Act, 1978	Gujarat Water Supply and Sewerage Board	Applicable (If the contractor is extracting surface water)	3 months	Contractor	Engineer
5	Permission for Sand	Mines and Minerals	Commissioner of	Applicable	2 month	Contractor	Engineer

¹As per submitted Forest Clearance Proposal in February/March 2012, forest department counts for trees to be cut this CoI are 5608. Subsequently design efforts tried to accommodate grownup green tunnels in proposed development.

² The right of permission vests with the Competent Authority

Sr. No.	Clearances	Acts	Approving Agency	Applicability to the Project	² Indicative Time Frame	Responsibility	
						Execution	Supervision
	Mining from river bed	(Development and Regulation) Act, 1957	geology and mining, GoG				
6	Permission for Opening of New Quarry	Mines and Minerals (Development and Regulation) Act, 1957	Commissioner of geology and mining, GoG	Applicable	2 month	Contractor	Engineer
7	Hot mix plant, Crushers, Cement Batching Plant	Air (Prevention and Control of Pollution) Act. 1981	Gujarat Pollution Control Board	Applicable	3 months	Contractor	Engineer
8	Storage of Hazardous Chemicals	Hazardous Waste (Management and Handling) Rules 1989 and Manufacturing Storage and Import of Hazardous Chemicals Rules 1989	Gujarat Pollution Control Board	Applicable	3 months	Contractor	Engineer
9	Disposal of Hazardous Waste	Hazardous Waste (Management and Handling) Rules 1989	Gujarat Pollution Control Board	Applicable	2 months	Contractor	Engineer
10	Disposal of Construction Waste and liquid effluent from Labour camps	Water (Prevention and Control of Pollution) Act 1974	Gujarat Pollution Control Board	Applicable	2 months	Contractor	Engineer
11	Pollution Under Control Certificate	Central Motor Vehicles Act 1988	Transport Department (GoG)	Applicable	1 Month	Contractor	Engineer
12	Employing Labour	Executing Agency of Building and other construction act, 1996	Labour & Employment Department, GoG	Applicable	1 Week	Contractor	Engineer
13	Registration of Workers	Labour welfare Acts.	Labour & Employment Department, GoG	Applicable	1 Month	Contractor	Engineer

Source: Acts, Rules and Regulation from Central and State Government

1.5 STRUCTURE OF THE REPORT

11. This report is structured to be a standalone document suitable for handing over to the contractor for enabling him to implement the suggested environmental management measures which has resulted due to EIA. Further to the introduction, this chapter also provides a summary of the environmental impacts and the necessary mitigation measures are detailed in Chapter 2. Environmental Management Plan is presented in Chapter 3, while the implementation arrangements for implementing the EMP are presented in the Chapter 4. Chapter 5 provides the necessary budget for implementing the EMP.

2. ENVIRONMENTAL ISSUES

2.1 SUMMARY OF IMPACTS

12. Environmental Impact Assessment was carried out for the project corridor and the impacts that are likely to arise from the implementation of the project are detailed along with suitable design measures in the Table 2.1.

Table 2.1: Summary of Environmental Impacts and Design Measures

Sl. No	Environmental and Social Impact	Design Measures
1.	A total of 5608 trees ³ are being impacted.	By adopting the CoI approach and the reduction of the formation width at Green Tunnel stretches, have resulted in the preservation of nearly 4346 trees from the impacts. As a management measure compensatory afforestation as directed by the forest department shall be carried out.
2.	Forest land diversion: 73.3ha of protected forest land needs to be diverted for widening and strengthening activity by adopting standard cross section.	By adopting CoI approach, the initial estimation of 73.3ha of protected forest land diversion has been reduced to 24.12ha. As a compensatory measure, the conditions for the diversion of forest land laid by the forest department shall be carried out.
3.	Impact on cultural properties: There are 2 cultural properties (a temple and a shrine) that are affected by adopting standard cross section.	By adopting the CoI approach and shifting of alignment, both the cultural properties are prevented from impact.
4.	Impact on topography/ Soil	The excavated material and scarified bitumen that are likely to be generated from the project corridor is estimated to be 16,000 and 54,320 cum respectively. Disposal of the debris will have impact on the local topography, hence as a resource recovery approach, the excavated waste shall be tested for the CBR values and if found suitable will be used as subgrade materials, for strengthening the embankment (or) as a strengthening layer for village and approach roads.
5.	As per the standard design the surface water bodies like 2 ponds are being affected due to their presence within the RoW	By adopting the CoI approach, the anticipated impacts on these water bodies are prevented. As a result of the design modification, none of the water bodies are being affected.
6.	Surface and ground water quality	Surface quality is found to be within permissible limits of prescribed drinking water standards and found suitable for construction and domestic purpose. The concentration of few physicochemical parameters like Chloride, Cadmium, Lead and Copper are observed to be exceeding the drinking water standards in case of groundwater quality. Hence, the contractor shall provide measures for treatment system of water prior to its utilisation. The extraction of the groundwater shall be done after obtaining clearance from the groundwater board, GoG, since the project corridor is located in a place which has been designated as safe zone by Ground Water Resource Development Centre (GWRDC).
7.	Air quality impact at the habitations/ settlements Vega village (Ch29+500), Simaliya (Ch39+300), Targol (Ch58+700) Bodeli junction (Ch68+200)	Air pollution due to construction yard will be particularly ground-based with localised effect during the construction period. It is suggested that the construction yard shall be located away from the settlement, all construction machineries (Crushers, Hot-mix Plants & Batching Plants) should be kept/stationed 1000m away from the settlements.
8.	Noise Pollution at Settlements and sensitive receptors Vega village (Ch29+500), Simaliya (Ch39+300), Targol (Ch58+700) Bodeli junction (Ch68+200) School at Ch54+000 and Hospital at Ch59+050	Noisy construction activities (such as crushing, concrete mixing, batching etc.) within 150m of the nearest habitation/ educational institutes/health centres (silence zones) shall be stopped during the night time between 9.00 pm to 6.00 am. Contractor shall provide noise barriers at the suggested locations at the identified locations viz., schools/ Temples/health centres prior to commencement of work.

³Estimated by Forest Department, GoG

2.2 SPECIFIC MEASURES

13. As part of the Environmental Assessment, consultations were held in the project corridor at various locations as given in Table 2.2. The outcome of the consultations was noted and for the discussed impacts, specific mitigation measures were suggested.

Table 2.2: Environmental and Social Specific Measures

Sl. No	Impact	Mitigation Measures
1.	Impact on residential/commercial structures and land acquisition Issues	<ul style="list-style-type: none"> 16m CoI approach has been adopted for minimising the social impacts associated with the residential/ commercial and land acquisition issues. For instances where unavoidable impact on land and structures are anticipated, compensation and assistance will be provided in line with the Resettlement Policy Framework (RPF) adopted for the project.
2.	Project corridor falls within the vicinity of Jambughoda Wildlife Sanctuary	<ul style="list-style-type: none"> The sanctuary is not declared as Eco sensitive zone. Consultation were held with the forest officials and the outcome of consultation suggests that since the project corridor (Dhaboi - Bodeli) is located in proximity to the sanctuary, it requires a 'No Objection Certificate' from the local DFO office. Proposal for the same has been submitted to the District Forest Officer (DFO) through State Road Project (SRP) Division, Vadodara for further action.
3.	Upgradation of the existing drains (bridges and culverts)	<ul style="list-style-type: none"> All the existing bridges, culverts and irrigation canals are proposed to be upgraded. The flood data collected from the irrigation department is used as a source for designing the drain provisions. Additional drain facility is also suggested at locations where water logging problem prevails.
4.	Safety issues need to be addressed in the proposed design	<ul style="list-style-type: none"> Road safety audit had been performed for the corridor and the outcome of the report and the public consultation has been taken as a base to provide road safety measures in the design. The safety measures includes provision of safety measures near settlements, Junction improvements, street lights etc. Due care has been taken at the social sensitive locations like schools and temples. Road design has been done as suggested by the local communities. Illustration of the design is depicted in the following figures.

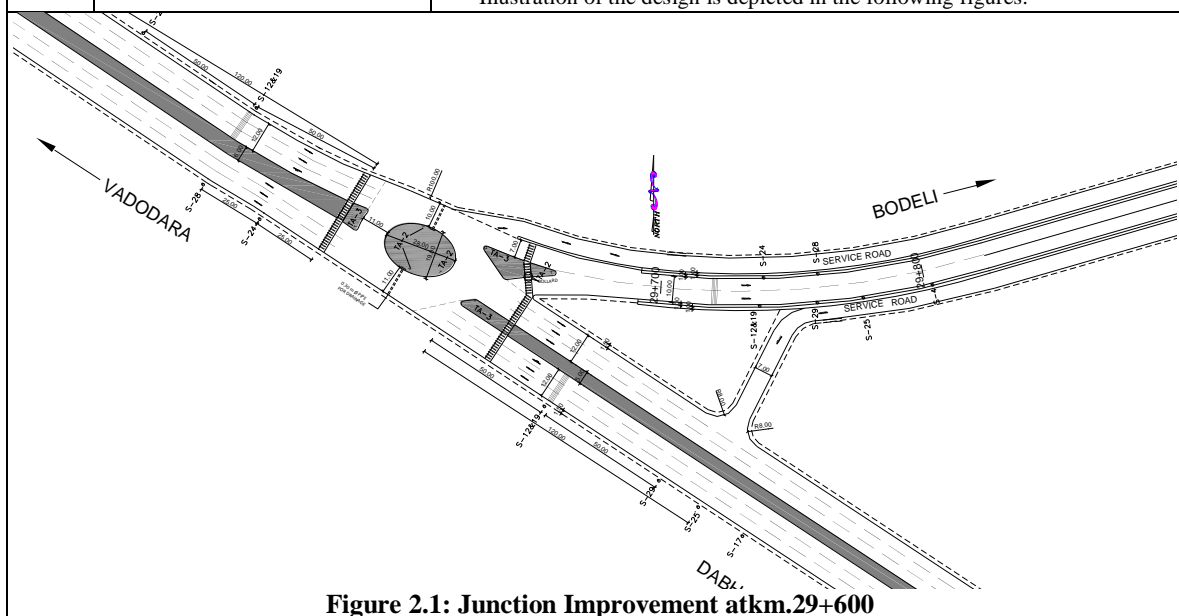
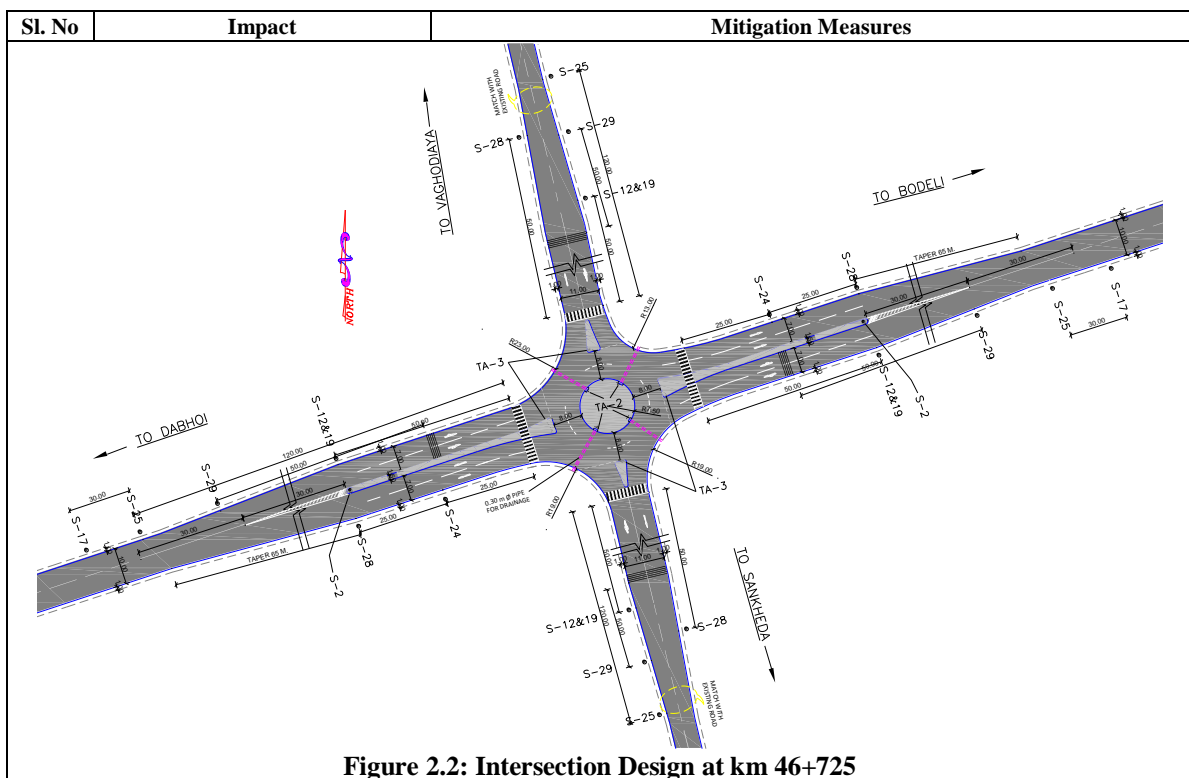

Figure 2.1: Junction Improvement at km.29+600



Sl. No	Impact	Mitigation Measures																																																																																																																																																																														
		<ul style="list-style-type: none"> Pansoli36+190 PansoliVasahat: Ch37+690 Simaliya: Ch39+495 Gopalpura School: Ch41+930 Narmada Vasahat School: Ch42+160 Kali Talavdi: Ch43+380 Gola Gamadi:46+620,46+825 Patra / Kurdi Junction: Ch56+490 Surya Ghoda: Ch58+690 Hospital Nera Surya Ghoda Village: Ch59+070 Bamroli: Ch 63+905 Bodeli Near Shop: Ch68+060 <p>Locations of Footpath are detailed below</p> <table border="1"> <thead> <tr> <th rowspan="2">Location</th> <th colspan="2">Chainage</th> </tr> <tr> <th>From</th> <th>To</th> </tr> </thead> <tbody> <tr><td>DarulUlaum School</td><td>31+255</td><td>31+440</td></tr> <tr><td>Lotiya/Dabhoi Junction</td><td>32+600</td><td>32+875</td></tr> <tr><td>Pansoli</td><td>36+125</td><td>36+285</td></tr> <tr><td>PansoliVasahat</td><td>37+600</td><td>37+700</td></tr> <tr><td>Simaliya</td><td>39+375</td><td>39+635</td></tr> <tr><td>Gopalpura</td><td>41+875</td><td>42+200</td></tr> <tr><td>Kali Talavdi</td><td>43+290</td><td>43+475</td></tr> <tr><td>GolaGamdi</td><td>45+325</td><td>45+410</td></tr> <tr><td>GolaGamdi</td><td>46+590</td><td>46+695</td></tr> <tr><td>GolaGamdi</td><td>46+735</td><td>46+850</td></tr> <tr><td>Lotiya/Bandharpur</td><td>48+660</td><td>48+865</td></tr> <tr><td>PaniyaVasahat</td><td>50+565</td><td>50+820</td></tr> <tr><td>Chuchapura</td><td>52+025</td><td>52+200</td></tr> <tr><td>BhadraliVasahat</td><td>53+945</td><td>54+115</td></tr> <tr><td>Kurdi/Patra</td><td>56+475</td><td>56+550</td></tr> <tr><td>Surya</td><td>58+250</td><td>58+700</td></tr> <tr><td>Surya Ghoda</td><td>58+975</td><td>59+125</td></tr> <tr><td>Patna/Sandhi</td><td>62+160</td><td>62+325</td></tr> <tr><td>Bamroli</td><td>63+900</td><td>64+025</td></tr> </tbody> </table>	Location	Chainage		From	To	DarulUlaum School	31+255	31+440	Lotiya/Dabhoi Junction	32+600	32+875	Pansoli	36+125	36+285	PansoliVasahat	37+600	37+700	Simaliya	39+375	39+635	Gopalpura	41+875	42+200	Kali Talavdi	43+290	43+475	GolaGamdi	45+325	45+410	GolaGamdi	46+590	46+695	GolaGamdi	46+735	46+850	Lotiya/Bandharpur	48+660	48+865	PaniyaVasahat	50+565	50+820	Chuchapura	52+025	52+200	BhadraliVasahat	53+945	54+115	Kurdi/Patra	56+475	56+550	Surya	58+250	58+700	Surya Ghoda	58+975	59+125	Patna/Sandhi	62+160	62+325	Bamroli	63+900	64+025																																																																																																																
Location	Chainage																																																																																																																																																																															
	From	To																																																																																																																																																																														
DarulUlaum School	31+255	31+440																																																																																																																																																																														
Lotiya/Dabhoi Junction	32+600	32+875																																																																																																																																																																														
Pansoli	36+125	36+285																																																																																																																																																																														
PansoliVasahat	37+600	37+700																																																																																																																																																																														
Simaliya	39+375	39+635																																																																																																																																																																														
Gopalpura	41+875	42+200																																																																																																																																																																														
Kali Talavdi	43+290	43+475																																																																																																																																																																														
GolaGamdi	45+325	45+410																																																																																																																																																																														
GolaGamdi	46+590	46+695																																																																																																																																																																														
GolaGamdi	46+735	46+850																																																																																																																																																																														
Lotiya/Bandharpur	48+660	48+865																																																																																																																																																																														
PaniyaVasahat	50+565	50+820																																																																																																																																																																														
Chuchapura	52+025	52+200																																																																																																																																																																														
BhadraliVasahat	53+945	54+115																																																																																																																																																																														
Kurdi/Patra	56+475	56+550																																																																																																																																																																														
Surya	58+250	58+700																																																																																																																																																																														
Surya Ghoda	58+975	59+125																																																																																																																																																																														
Patna/Sandhi	62+160	62+325																																																																																																																																																																														
Bamroli	63+900	64+025																																																																																																																																																																														
6.	Crash barrier	<ul style="list-style-type: none"> Guard rails on both sides are provided at sharp curves along with signage's to provide necessary safety while crossing such curves. The locations are at 																																																																																																																																																																														
		<table border="1"> <thead> <tr> <th colspan="3">LHS</th> <th colspan="3">RHS</th> </tr> <tr> <th>Location</th> <th>From</th> <th>To</th> <th>Location</th> <th>From</th> <th>To</th> </tr> </thead> <tbody> <tr> <td>Pond</td> <td>30+450</td> <td>30+525</td> <td>Lotiya/ Dabhoi Junction</td> <td>32+875</td> <td>33+000</td> </tr> <tr><td>Green Tunnel</td><td>33+900</td><td>35+450</td><td>Green Tunnel</td><td>33+900</td><td>35+450</td></tr> <tr><td>Near Simaliya</td><td>39+900</td><td>40+150</td><td>Green Tunnel</td><td>43+900</td><td>45+275</td></tr> <tr><td>Green Tunnel</td><td>43+900</td><td>45+275</td><td>Green Tunnel</td><td>45+425</td><td>45+500</td></tr> <tr><td>Green Tunnel</td><td>45+425</td><td>47+865</td><td>Green Tunnel</td><td>47+500</td><td>47+865</td></tr> <tr><td>Green Tunnel</td><td>47+925</td><td>48+575</td><td>Green Tunnel</td><td>47+925</td><td>48+575</td></tr> <tr><td>Green Tunnel</td><td>49+050</td><td>49+600</td><td>Green Tunnel</td><td>49+050</td><td>49+440</td></tr> <tr><td>Green Tunnel</td><td>49+750</td><td>50+000</td><td>Green Tunnel</td><td>49+465</td><td>49+600</td></tr> <tr><td>Green Tunnel</td><td>50+900</td><td>51+020</td><td>Green Tunnel</td><td>49+750</td><td>50+000</td></tr> <tr><td>Green Tunnel</td><td>51+130</td><td>52+000</td><td>Green Tunnel</td><td>50+900</td><td>51+020</td></tr> <tr><td>Green Tunnel</td><td>52+225</td><td>52+900</td><td>Green Tunnel</td><td>51+130</td><td>52+000</td></tr> <tr><td>Structure</td><td>52+850</td><td>52+900</td><td>Green Tunnel</td><td>52+225</td><td>52+900</td></tr> <tr><td>Structure</td><td>52+915</td><td>52+970</td><td>Green Tunnel</td><td>52+850</td><td>52+900</td></tr> <tr><td>Green Tunnel</td><td>54+750</td><td>54+800</td><td>Green Tunnel</td><td>52+915</td><td>52+970</td></tr> <tr><td>Green Tunnel</td><td>54+825</td><td>55+180</td><td>Green Tunnel</td><td>54+750</td><td>54+800</td></tr> <tr><td>Green Tunnel</td><td>55+325</td><td>56+000</td><td>Green Tunnel</td><td>54+825</td><td>55+180</td></tr> <tr><td>Green Tunnel</td><td>56+000</td><td>56+080</td><td>Green Tunnel</td><td>55+325</td><td>56+000</td></tr> <tr><td>Green Tunnel</td><td>56+105</td><td>56+470</td><td>Green Tunnel</td><td>56+000</td><td>56+470</td></tr> <tr><td>Green Tunnel</td><td>56+600</td><td>58+275</td><td>Green Tunnel</td><td>56+600</td><td>58+275</td></tr> <tr><td>Green Tunnel</td><td>58+370</td><td>58+465</td><td>Green Tunnel</td><td>58+370</td><td>58+465</td></tr> <tr><td>Green Tunnel</td><td>59+200</td><td>59+725</td><td>Green Tunnel</td><td>59+200</td><td>59+525</td></tr> <tr><td>Green Tunnel</td><td>59+825</td><td>60+780</td><td>Green Tunnel</td><td>59+575</td><td>59+725</td></tr> <tr><td>Green Tunnel</td><td>60+500</td><td>62+600</td><td>Green Tunnel</td><td>59+825</td><td>60+780</td></tr> <tr><td>Green Tunnel</td><td>60+890</td><td>60+930</td><td>Green Tunnel</td><td>60+890</td><td>60+930</td></tr> <tr><td>Green Tunnel</td><td>61+225</td><td>62+175</td><td>Green Tunnel</td><td>61+225</td><td>62+175</td></tr> <tr><td>Green Tunnel</td><td>62+350</td><td>62+525</td><td>Green Tunnel</td><td>62+350</td><td>63+700</td></tr> <tr><td>Green Tunnel</td><td>62+575</td><td>63+320</td><td>Green Tunnel</td><td>62+600</td><td>63+600</td></tr> </tbody> </table>	LHS			RHS			Location	From	To	Location	From	To	Pond	30+450	30+525	Lotiya/ Dabhoi Junction	32+875	33+000	Green Tunnel	33+900	35+450	Green Tunnel	33+900	35+450	Near Simaliya	39+900	40+150	Green Tunnel	43+900	45+275	Green Tunnel	43+900	45+275	Green Tunnel	45+425	45+500	Green Tunnel	45+425	47+865	Green Tunnel	47+500	47+865	Green Tunnel	47+925	48+575	Green Tunnel	47+925	48+575	Green Tunnel	49+050	49+600	Green Tunnel	49+050	49+440	Green Tunnel	49+750	50+000	Green Tunnel	49+465	49+600	Green Tunnel	50+900	51+020	Green Tunnel	49+750	50+000	Green Tunnel	51+130	52+000	Green Tunnel	50+900	51+020	Green Tunnel	52+225	52+900	Green Tunnel	51+130	52+000	Structure	52+850	52+900	Green Tunnel	52+225	52+900	Structure	52+915	52+970	Green Tunnel	52+850	52+900	Green Tunnel	54+750	54+800	Green Tunnel	52+915	52+970	Green Tunnel	54+825	55+180	Green Tunnel	54+750	54+800	Green Tunnel	55+325	56+000	Green Tunnel	54+825	55+180	Green Tunnel	56+000	56+080	Green Tunnel	55+325	56+000	Green Tunnel	56+105	56+470	Green Tunnel	56+000	56+470	Green Tunnel	56+600	58+275	Green Tunnel	56+600	58+275	Green Tunnel	58+370	58+465	Green Tunnel	58+370	58+465	Green Tunnel	59+200	59+725	Green Tunnel	59+200	59+525	Green Tunnel	59+825	60+780	Green Tunnel	59+575	59+725	Green Tunnel	60+500	62+600	Green Tunnel	59+825	60+780	Green Tunnel	60+890	60+930	Green Tunnel	60+890	60+930	Green Tunnel	61+225	62+175	Green Tunnel	61+225	62+175	Green Tunnel	62+350	62+525	Green Tunnel	62+350	63+700	Green Tunnel	62+575	63+320	Green Tunnel	62+600	63+600
LHS			RHS																																																																																																																																																																													
Location	From	To	Location	From	To																																																																																																																																																																											
Pond	30+450	30+525	Lotiya/ Dabhoi Junction	32+875	33+000																																																																																																																																																																											
Green Tunnel	33+900	35+450	Green Tunnel	33+900	35+450																																																																																																																																																																											
Near Simaliya	39+900	40+150	Green Tunnel	43+900	45+275																																																																																																																																																																											
Green Tunnel	43+900	45+275	Green Tunnel	45+425	45+500																																																																																																																																																																											
Green Tunnel	45+425	47+865	Green Tunnel	47+500	47+865																																																																																																																																																																											
Green Tunnel	47+925	48+575	Green Tunnel	47+925	48+575																																																																																																																																																																											
Green Tunnel	49+050	49+600	Green Tunnel	49+050	49+440																																																																																																																																																																											
Green Tunnel	49+750	50+000	Green Tunnel	49+465	49+600																																																																																																																																																																											
Green Tunnel	50+900	51+020	Green Tunnel	49+750	50+000																																																																																																																																																																											
Green Tunnel	51+130	52+000	Green Tunnel	50+900	51+020																																																																																																																																																																											
Green Tunnel	52+225	52+900	Green Tunnel	51+130	52+000																																																																																																																																																																											
Structure	52+850	52+900	Green Tunnel	52+225	52+900																																																																																																																																																																											
Structure	52+915	52+970	Green Tunnel	52+850	52+900																																																																																																																																																																											
Green Tunnel	54+750	54+800	Green Tunnel	52+915	52+970																																																																																																																																																																											
Green Tunnel	54+825	55+180	Green Tunnel	54+750	54+800																																																																																																																																																																											
Green Tunnel	55+325	56+000	Green Tunnel	54+825	55+180																																																																																																																																																																											
Green Tunnel	56+000	56+080	Green Tunnel	55+325	56+000																																																																																																																																																																											
Green Tunnel	56+105	56+470	Green Tunnel	56+000	56+470																																																																																																																																																																											
Green Tunnel	56+600	58+275	Green Tunnel	56+600	58+275																																																																																																																																																																											
Green Tunnel	58+370	58+465	Green Tunnel	58+370	58+465																																																																																																																																																																											
Green Tunnel	59+200	59+725	Green Tunnel	59+200	59+525																																																																																																																																																																											
Green Tunnel	59+825	60+780	Green Tunnel	59+575	59+725																																																																																																																																																																											
Green Tunnel	60+500	62+600	Green Tunnel	59+825	60+780																																																																																																																																																																											
Green Tunnel	60+890	60+930	Green Tunnel	60+890	60+930																																																																																																																																																																											
Green Tunnel	61+225	62+175	Green Tunnel	61+225	62+175																																																																																																																																																																											
Green Tunnel	62+350	62+525	Green Tunnel	62+350	63+700																																																																																																																																																																											
Green Tunnel	62+575	63+320	Green Tunnel	62+600	63+600																																																																																																																																																																											

Sl. No	Impact	Mitigation Measures					
		Near Patna Junction	62+600	63+600	Green Tunnel	63+750	63+900
		Green Tunnel	63+440	63+700	Green Tunnel	65+500	65+636
		Green Tunnel	63+750	63+900	Green Tunnel	66+450	67+300
		Green Tunnel	65+500	65+636			
		Narmada Main Canal	66+450	67+300			
		Green Tunnel	45+425	47+865			
		Green Tunnel	47+925	48+575			
7.	Bus stop	<ul style="list-style-type: none"> The Bus stops are identified either sides of the corridor and the locations are: 					
		Chainage	Village		Side	Remarks	
		Use existing bus stop			RHS	Only bus bay	
		29+635	Vega		LHS	New	
		31+410	DarulUmaum Vega		RHS	New	
		31+290			LHS	New	
		32+870	Timbi		LHS	New	
		32+740	Dabhoi		RHS	New	
		36+150	Pansoli		RHS	Only bus bay	
		36+250			LHS	New	
		36+500	Akotadar		RHS	Only bus bay	
		37+650	PansoliVasahat		RHS	New	
		39+400	Simaliya		RHS	New	
		39+600			LHS	New	
		41+535	Motipura		LHS	Only bus bay	
		41+900	Gopalpura		RHS	Only bus bay	
		42+010			LHS	New	
		43+310	Kali Talavdi		RHS	Only bus bay	
		43+435			LHS	New	
		45+315	Virnarmad university		LHS	New	
		46+575	GolaGamdi		RHS	New	
		46+870			LHS	New	
		48+700	Lotiya / Bandarpur		RHS	Only bus bay	
		48+830			LHS	New	
		49+660	Paniya		RHS	Only bus bay	
		50+590	PaniyaVasahat		RHS	New	
		50+790			LHS	New	
		52+050	Chuchapura		RHS	Only bus bay	
		52+170			LHS	New	
		53+975	School near Bhadrailivasahat		RHS	New	
		54+080			LHS	New	
		55+230	Dormar		RHS	Only bus bay	
		56+535	Kundi		LHS	Only bus bay	
		58+325	Surya		LHS	Only bus bay	
		58+720	Surya		RHS	Only bus bay	
		59+025	Hospital near Surya ghoda village		RHS	New	
		59+760	Jojava		LHS	Only bus bay	
		60+825	Pitha		LHS	Only bus bay	
		62+200	Patna / Sandhi junction		LHS	Only bus bay	
		62+275	Patna / Sandhi junction		RHS	New	
		63+950	Bamroli		LHS	Only bus bay	
		63+960			RHS	Only bus bay	
		65+305	Kadila		RHS	Only bus bay	
		65+655	Charola		RHS	Only bus bay	

2.3 ENHANCEMENT MEASURES

14. As an enhancement measure, a temple at Ch32+800 has been chosen to provide some basic amenities; the selection is based on the consultation held with the communities. The suggested amenities / enhancement drawings for the cultural property are given in the Appendix 3. Budget estimation for enhancement measures is given in the EMP Budget.

Table 2.3: Selected Enhancement Measures for Proposed Project corridor

S. No.	Chainage	Name of Structure	Side	Distance from CL (m)	Age (in Years)	Size	Ownership	Building type
1	32+800	Hanuman Temple	LHS	25	20	Large	Private	Pucca

15. The project corridor does not have any incidental spaces. Hence development of parking area in the incidental space is not envisaged.

3. ENVIRONMENTAL MANAGEMENT PLAN

16. A description of the various management measures during various stages of the project are provided in Table 3.1.

3.1 PRE-CONSTRUCTION STAGE

3.1.1 Pre-Construction Activities by PIU

17. Prior to the Contractor mobilization, the PIU will ensure that an encumbrance free CoI is handed over to enable the start of construction. The RoW clearance involves the following activities:

- Clearance of the RoW includes removal of trees, and
- Relocation of common property resources impacted, including cultural properties as temples and community assets as hand pumps and other utilities

3.1.2 By Contractor/Engineer

18. The pre-construction stage involves mobilization of the Contractor, the activities undertaken by the Contractor pertaining to the planning of logistics and site preparation necessary for commencing construction activities. The activities include:

- Modification (if any) of the contract documents by the Engineer
- Procurement of construction equipment / machinery such as crushers, hot mix plants, batching plants and other construction equipment and machinery
- Identification and selection of material sources (quarry and borrow material, water, sand etc.)
- Selection, design and layout of construction areas, hot mix and batching plants, labour camps etc.
- Planning traffic diversions and detours, including arrangements for temporary land acquisition

3.2 CONSTRUCTION STAGE

3.2.1 Construction stage activities by the contractor

19. Construction stage activities require careful management to avoid environmental impacts. Activities that trigger the need for environmental measures to be followed include:

- Imbibing environmental principles at all stages of construction as good engineering practices
- Implementation of site-specific mitigation/management measures suggested
- Monitoring the quality of environment along the construction sites (as air, noise, water and soil)

20. There are several other environmental issues that have been addressed as part of good engineering practices, the costs for which have been accounted in the engineering costs. They include improvement of roadside drainage, provision of additional cross drainage structures

or raising the road height in low-lying stretches, reconstruction and improvement of bunds of the affected water bodies.

3.3 OPERATION STAGE

21. Monitoring of the environmental attributes during the initial years of operation of the road shall be carried out by the Contractor as laid down in the monitoring plan, under the supervision of the Engineer.

Table 3.1: Environmental Management Plan

Environmental Issues		Ref: Clauses	Additional Measures to be Adopted by the Contractor	Location ⁴	Responsibility	
I. Pre-Construction Stage						
1.1. Pre-construction activities by PIU						
	1.1.1.	Utility Relocation and Common Property Resources (CPRs)	Clause 110.1. and 110.7 of MoRTH	<ul style="list-style-type: none"> PIU and concerned line departments shall take necessary precautions, and shall provide barricades/delineation of such sites to prevent accidents including accidental fall into bore holes, pits, drains both during demolition and construction/ relocation of such facilities. Standard safety practices shall be adopted for all such works. 	Corridor of Impact.	PIU
1.2. Pre-construction activities by the Contractor/Engineer						
	1.2.1.	Joint Field Verification		<ul style="list-style-type: none"> The Engineer and Contractor shall ascertain the feasibility of implementing the Environmental Management Plan (EMP) through Joint field verification. Any observations / modification required in updating EMP shall be done by the Engineer and a copy of the modified EMP shall be submitted to the PIU for review and approval. 	Along the project corridor	Contractor under the supervision of the Engineer
	1.2.2.	Procurement of Machinery				
	1.2.2.1	Crushers, Hot-mix Plants & Batching Plants	(i) Emission control legislations of CPCB/ GPCB for air, noise etc. (ii) Clause 111.5 of MoRTH (Pollution from Hot mix and Batching Plant)	<ul style="list-style-type: none"> The contractor shall follow all stipulated conditions for pollution control as suggested by the GPCB in the consent/ NoC for establishing and operating the Hot-mix and Batching Plant. No such installation by the Contractor shall be allowed till all the required legal clearances are obtained from the competent authority and the same is submitted to the PIU. The location of the hot-mix and batching plant shall be at least (i) 1000m away from settlements and shall be placed in the downwind direction and (ii) 10 km aerial distance away from the protected areas (sanctuary, national parks etc.). 	All construction machineries (Crushers, Hot-mix Plants & Batching Plants) should be kept/stationed 1000m away from settlements: <ul style="list-style-type: none"> Vega village (Ch29+500), Simaliya (Ch39+300), Targol (Ch58+700) Bodeli junction (Ch68+200) 	Contractor under the supervision of the Engineer
				<ul style="list-style-type: none"> The contractor shall submit the detailed layout plan for approval to the Engineer before getting into formal agreement with landowners for setting up of such site. Actions by Engineer and PIU against any non-compliance shall be borne by the Contractor at his own cost 	Sensitive location: Vadhvana reservoir (Ch39+400), School (Ch54+000) and Hospital (Ch59+050)	
	1.2.2.2.	Other Construction Vehicles, Equipment and Machinery	Discharge standards and Noise limits as per Environment Protection Act, 1986 (EPA) Emission standards as per Bureau of Indian Standard (BIS) preferably Bharat IV emission norms	<ul style="list-style-type: none"> Equipment's conforming to the latest noise and emission control measures shall be used. Pollution under Control (PUC) certificates for all vehicles and machinery shall be made available to the Engineer and PIU for verification whenever required. 	Along the project corridor	Contractor under the supervision of the Engineer

⁴ All locations are referred to design chainages

Environmental Issues		Ref: Clauses	Additional Measures to be Adopted by the Contractor	Location ⁴	Responsibility	
	1.2.3.	Identification & Selection of Material Sources				
	1.2.3.1.	Borrow Areas	Clause 305.2.2. of MoRTH Clause 111.2 (borrow pits for embankment construction)	<ul style="list-style-type: none"> The Engineer shall inspect every borrow area location prior to issuing approval for use of such sites. Care shall be taken to avoid agriculture areas for planning haul roads for accessing borrow materials. In case of damage, the contractor shall be solely responsible and shall rehabilitate it, as approved by Engineer. All borrow areas shall be restored either to the original condition or as per the approved rehabilitation plan by the Engineer, immediately upon completion of the use of such a source. 	Source of borrow area at : Vaga village(Ch30+750) Pancholi village (Ch37+500), RHS of Corridor(Ch54+500)	Contractor under the supervision of the Engineer
	1.2.3.2.	Quarries	Clause 111.3. of MoRTH (procuring Quarry materials)	<ul style="list-style-type: none"> No quarry and/or crusher units shall be established, which is within 1000m from the residential/ settlement locations, forest boundary, wildlife movement path, breeding and nesting habitats and national parks/sanctuaries. Contractor shall work out haul road network to be used for transport of quarry materials and report to Engineer who shall inspect and approve the same. 	Nearest Quarry locations are at: Apollo, Othawad, National (SH-83, 151), Shiv Shakti, Sevaliya (Ch0+000, 19+150),SH- 83, 151 Quarry area should be located 1000m from the following locations: (i) Settlement locations: <ul style="list-style-type: none"> Vega village (Ch29+500), Simaliya (Ch39+300), Targol (Ch58+700) Bodeli junction (Ch68+200) 	Contractor under the supervision of the Engineer
	1.2.3.3.	Arrangement for Construction Water		<ul style="list-style-type: none"> The contractor shall source the requirement of water preferably from surface water bodies, rivers, canals and tanks in the project area. To avoid disruption/disturbance to other water users, the contractor shall extract water from fixed locations. The contractor shall consult the local people before finalizing the locations. Only at locations where surface water sources are not available, the contractor can contemplate extraction of ground water, after intimation and consent from the Engineer. The contractor shall comply with the requirements of Gujarat Groundwater Authority and seek their approval for extraction of ground water. 	All rivers / surface water bodies that can be utilized within the project area at the following locations	Contractor under the supervision of the Engineer
	1.2.3.4.	Sand (all river and stream beds used directly or indirectly for the project)	Clause 111.3. of MoRTH	<ul style="list-style-type: none"> In case of selection of new sites for sand quarrying, the Contractor shall obtain prior approval and concurrence from Competent District Authority. To avoid accidents and caving in of sand banks at quarry sites, sand shall be removed layer by layer. Digging deeper than the permissible limit (0.9 metres) shall not be allowed. Such quarry shall be barricaded 10m away from the periphery on all sides except the entry point, so as to prevent accidental fall of domestic cattle, wildlife and human beings. 	Nearest sand quarries locations: Orsang River, Near Bodeli (Ch 68+000, SH-11)	Contractor under the supervision of the Engineer
	1.2.4.	Setting up construction sites				

Environmental Issues		Ref: Clauses	Additional Measures to be Adopted by the Contractor	Location ⁴	Responsibility
	1.2.4.1	Construction Camp Locations – Selection, Design & Layout	Construction camps shall not be proposed: (i) Within 1000m of ecologically sensitive areas (if any) (ii) Within 1000m from the nearest habitation to avoid conflicts and stress over the infrastructure facilities, with the local community	(i) Sensitive areas : Vadhavan reservoir (Ch40+000) (ii) Nearest Habitations: • Vega village (Ch29+500), • Simaliya (Ch39+300), • Targol (Ch58+700) • Bodeli junction (Ch68+200)	Contractor under the supervision of the Engineer
	1.2.4.2.	Arrangements for Temporary Land Requirement	Clause 108.3. of MoRTH • The Engineer shall ensure that the temporary site is cleared prior to handing over to the owner (after construction or completion of the activity) and it is included in the contract	Areas temporarily acquired for construction sites / hot mix plants / borrow areas / diversions / detours	Contractor under the supervision of the Engineer
	1.2.4.3.	Stock-yards	• The contractor shall identify the location for stockyards for construction materials at least 1000m from water courses. • Separate enclosures shall be planned for storing construction materials containing fine particles such that sediment-laden water does not drain into nearby storm water drains	Construction labor camps Nearest water body locations are at : Ponds (Ch30+700 and 45+900), Canal crossings: Minor (Ch48+700, 51+050, 55+200, 59+350, (61+600), Major (Ch66+850), Drainages: (Ch34+175, 44+480, 54+775)	Contractor under the supervision of the Engineer
	1.2.4.4.	Fuel storage and refuelling areas	Clause 2.1.1.7. of EMP (Stripping of Soil) Clause 2.1.4.1.2 of EMP (dispose the spent oil and grease) • The contractor shall ensure that all construction vehicle parking locations, fuel/lubricants storage sites, vehicle, machinery and equipment maintenance and refuelling sites are located at least 500 m from rivers and irrigation canal/ponds.	Construction labor camps Canals and Ponds locations are at: Water body location: Ponds (Ch30+700 and 45+900), Canal crossings: Minor (Ch48+700, 51+050, 55+200, 59+350, (61+600), Major (Ch66+850), Drainages: (Ch34+175, 44+480, 54+775)	Contractor under the supervision of the Engineer
	1.2.5.	Labour Camp Management			
	1.2.5.1	Location of Construction labour camps: Accommodation	Factories Act, 1948 and Building & other Construction Workers (Regulation of Employment and Conditions of Service) Act, 1996 (construction & maintenance of labor camp) • The contractor shall provide, if required, erect and maintain necessary (temporary) living accommodation and ancillary facilities for labourers, to standards approved by the Engineer. • Labour camps shall not be located within 1000m from the nearest habitation to avoid conflicts and stress over the infrastructure facilities, with the local community. The location, layout and basic facility provision of labour camps shall be submitted to Engineer for approval prior to construction.	Along the project corridor at the location of construction labor camps	Contractor under the supervision of the Engineer
	1.2.5.2	Potable Water	The Contract Labour (Regulation and Abolition) Act, 1970 and Factories Act, 1948 • The contractor shall supply portable water through municipal/ panchayat sources. In case of groundwater it shall be treated prior to supply.	Construction labor camps	Contractor under the supervision of the Engineer

Environmental Issues			Ref: Clauses	Additional Measures to be Adopted by the Contractor	Location ⁴	Responsibility
	1.2.5.3	Sanitation facilities	Factories Act, 1948 for sanitation	<ul style="list-style-type: none"> The sanitation facilities for the camp shall be designed, built and operated in such a fashion that no health hazards occurs and no pollution to the air, ground water or adjacent water courses take place. 	Construction labor camps	Contractor under the supervision of the Engineer
	1.2.5.4	Waste Disposal	Municipal Solid Waste (Management and Handling) Rules – 2000 for effective waste disposal	<ul style="list-style-type: none"> The contractor shall provide garbage bins in the camps and ensure that these are regularly emptied and disposed off in a hygienic manner 	Construction labor camps	Contractor under the supervision of the Engineer
	1.2.5.5	HIV/ AIDS Prevention Measures		<ul style="list-style-type: none"> The Contractor shall implement the following measures towards ensuring HIV/AIDS prevention during the entire contract period (i) conduct awareness campaign including dissemination of IEC materials on HIV/AIDS for all construction personnel (including labourers, supervisors, engineers and consultants) on HIV/AIDS/STDs within 3 months of mobilization and once a year subsequently during the contract period; (ii) carry out screening of construction personnel for HIV/ AIDS, within the 3 month of mobilisation (iii) conduct semi-annual health check-up of all construction personnel including testing for STDs; (iv) erect and maintain hoardings/ information signages on HIV/AIDS prevention at the construction sites, labour camps and truck parking locations; (v) install condom vending machines at the labour camps, including replenishment of supplies. 	Construction & labor camps	Contractor under the supervision of the Engineer
2. CONSTRUCTION STAGE						
2.1. Construction Stage Activities by Contractor						
	2.1.1.	Site Clearance				
	2.1.1.1.	Clearing and Grubbing	Clause 201. of MoRTH	<ul style="list-style-type: none"> All works shall be carried out in a manner such that the damage or disruption to flora is minimal. Only ground cover/shrubs that impinge directly on the permanent works or necessary temporary works shall be removed with prior approval from the Engineer. 	Along the project corridor at construction sites	
	2.1.1.2.	Dismantling of Bridgework/ Culverts	Clause 202. Of MoRTH	<ul style="list-style-type: none"> The contractor shall follow all necessary measures (including safety) especially while working close to cross drainage channels to prevent earthwork, stonework, materials and appendages from impeding cross drainage at rivers, streams, water canals and existing irrigation and drainage systems. 	At locations where bridge works and culverts are proposed. Bridge locations at:Ch44+330, 50+900, 56+100, 59+150, 61+500, 62+900, 65+025, 66+800 Culvert locations: Culverts: 25 proposed culverts and 17 existing culverts	Contractor under the supervision of the Engineer

Environmental Issues		Ref: Clauses	Additional Measures to be Adopted by the Contractor	Location ⁴	Responsibility
	2.1.1.3. Generation & disposal of Debris	Clause 202.5 of MoRTH. For Disposal of materials	<ul style="list-style-type: none"> Disposal of unutilized non-toxic debris shall be either through filling up of borrow areas or at pre-designated disposal sites, subject to the approval of the Engineer. At locations identified for the disposal of residual bituminous wastes, the disposal shall be carried out on top of a 60 mm thick layer of rammed clay so as to eliminate the possibility of leaching of wastes into the ground water. Debris generated due to the driving of piles or other construction activities along the rivers, streams and drainage channels shall be carefully disposed in such a manner that it does not flow into the surface water bodies or form puddles in the area. The pre-designated disposal locations shall be part of Comprehensive Solid Waste Management Plan that has to be prepared by the Contractor in consultation and with approval of Engineer. 	Throughout Project Corridor	Contractor under the supervision of the Engineer
	2.1.1.4. Non-bituminous construction wastes disposal	Clause 202. Of MoRTH	<ul style="list-style-type: none"> The contractor shall finalise the location of disposal sites based on the following. <ul style="list-style-type: none"> not located within designated forest area does not impact natural drainage courses No endangered/rare flora is impacted by such dumping. Settlements are located at least 1000m away from the site. <p>The Engineer shall approve disposal sites after conformation</p>	Disposal site locations	Contractor under the supervision of the Engineer
	2.1.1.5. Bituminous wastes disposal	Clause 202.5. of MoRTH	<ul style="list-style-type: none"> The disposal of residual bituminous wastes shall be done by the contractor at secure land fill sites, with the requisite approvals for the same from the concerned government agencies. 	Disposal site locations	Contractor under the supervision of the Engineer
	2.1.1.6. Stripping, stacking and preservation of top soil	<p>Clause 301.3.2 for stripping and preservation</p> <p>Clause 305.3.3 for construction and for embankments</p> <p>Clause 301.7. for preservation of Top Soil</p>	<ul style="list-style-type: none"> Contractor shall strip the topsoil at all locations that has been opened up for construction, including temporarily acquired land for traffic detours, storage, materials handling or any other construction related or incidental activities. 	At all construction sites	Contractor under the supervision of the Engineer
	2.1.1.7. Accessibility		<ul style="list-style-type: none"> The Contractor shall provide safe and convenient passage for vehicles; pedestrians and livestock to and from roadsides and property accesses by providing temporary connecting road, as necessary. Construction activities that shall affect the use of side roads and existing accesses to individual properties, whether public or private, shall not be undertaken without providing adequate provisions to ensure uninterrupted access, as approved by the Engineer. The Contractor shall take care that the cross roads are constructed in such a sequence that construction work over the adjacent cross roads are taken up in a manner that traffic movement in any given area does not get affected. 	Throughout Project Corridor	Contractor under the supervision of the Engineer

Environmental Issues		Ref: Clauses	Additional Measures to be Adopted by the Contractor	Location ⁴	Responsibility	
	2.1.1.8.	Planning for Traffic Diversions and Detours	Clause 112. of MoRTH	<ul style="list-style-type: none"> Detailed traffic control plans shall be prepared by the contractor and the same shall be submitted to the Engineer. The Contractor shall provide specific measures for safety of pedestrians and workers as a part of traffic control plans. The Contractor shall ensure that the diversion/detour is always maintained in running condition, particularly during the monsoon to avoid disruption to traffic flow. The Contractor shall inform local community of changes in traffic routes and pedestrian access arrangements with assistance from Engineer and PIU. 	All along the project corridor, all access roads. Attention is required at: <ul style="list-style-type: none"> Vega village (Ch29+500), Simaliya (Ch39+300), Targol (Ch58+700) Bodeli junction (Ch68+200) 	Contractor under the supervision of the Engineer
	2.1.2.	Construction Materials				
	2.1.2.1.	Earth from Borrow Areas for Construction	IRC 010-1961 (procurement of earth materials)		All along the project corridor, all access roads, temporarily acquired sites & all borrow areas	Contractor under the supervision of the Engineer
	2.1.2.2.	Quarries	Clause 111.3. of MoRTH (procurement of materials)		Nearest Quarry locations: Apollo, Othawad, National (SH-83, 151), Shiv Shakti, Sevaliya (Ch0+000, 19+150), SH- 83, 151	Contractor under the supervision of the Engineer
	2.1.2.3.	Blasting	Clause of 302. Of MoRTH		All blasting and Pre-splitting Sites.	Contractor under the supervision of the Engineer
	2.1.2.4.	Transporting Construction Materials	Clause 111.9. of MoRTH	<ul style="list-style-type: none"> All vehicles that are delivering materials to the site shall be covered to avoid spillage of materials. The unloading of materials at construction sites close to settlements shall be restricted to daytime only. 	All along the Project corridor and all haul roads	Contractor under the supervision of the Engineer
	2.1.3.	Construction work				
	2.1.3.1.	Disruption to other users of Water	Annexure “A” Protection of the Environment of MoRTH and Clause 2 Water Quality of MoRTH	<ul style="list-style-type: none"> In case of diversion of water bodies, the Contractor shall take prior approval from the Irrigation Department and Engineer for any such activity. The PIU shall ensure that Contractor has served a notice to the downstream users of water, well in advance, where such diversion of the flow is likely to affect the downstream population subject to the condition that under no circumstances the downstream flow shall be stopped. 		Contractor under the supervision of the Engineer

Environmental Issues		Ref: Clauses	Additional Measures to be Adopted by the Contractor	Location ⁴	Responsibility	
	2.1.3.2.	Drainage and Flood Control	Clause 202. Of MoRTH	<ul style="list-style-type: none"> Contractor shall ensure that construction materials like earth, stone, ash or appendages disposed off does not block the flow of water of any water course and cross drainage channels. Where necessary, adequate mechanical devices to bailout accumulated water from construction sites, camp sites, storage yard, excavation areas are to be arranged well in advance before the rainy season besides providing temporary cross drainage systems. The contractor shall take all adequate precautions to ensure that construction materials and excavated materials are enclosed in such a manner that erosion or run-off of sediments is controlled. Silt fencing shall be installed prior to the onset of the monsoon at all the required locations, as directed by Engineer and PIU. The contractor shall ensure that no material blocks the natural flow of water in any water course or cross drainage channel. Prior to monsoon, the contractor shall provide either permanent or temporary drains to prevent water logging. 	Surface water sources/ drains/ Nalahs/ Ponds etc. Silt fencing should be given near at: Water body location: Ponds (Ch30+700 and 45+900), Canal crossings: Minor (Ch48+700, 51+050, 55+200, 59+350, (61+600), Major (Ch66+850), Drainages: (Ch34+175, 44+480, 54+775)	Contractor under the supervision of the Engineer
	2.1.3.3.	Siltation of Water Bodies and Degradation of Water Quality	Clause 306. of MoRTH for soil erosion and sedimentation control		Surface water sources/ drains/ Nalahs/ Ponds etc. Silt fencing at: Water body location: Water body location: Ponds (Ch30+700 and 45+900), Canal crossings: Minor (Ch48+700, 51+050, 55+200, 59+350, (61+600), Major (Ch.66+850), Drainages: (Ch34+175, 44+480, 54+775)	Contractor under the supervision of the Engineer
	2.1.3.4.	Slope Protection and Control of Soil Erosion	Clause 306. of MoRTH for soil erosion and sedimentation control Clause 307. of MoRTH for Turfing works Clause 308. of MoRTH for other measures of Slope Protection	<ul style="list-style-type: none"> The contractor shall construct slope protection as per the design or as directed by the Engineer 	High raise embankments and surface water bodies locations have been carried out by adopting Stone Pitching method at Canal crossings: Minor (Ch48+700, 51+050, 55+200, 59+350, (61+600), Major (Ch66+850), Drainages: (Ch34+175, 44+480, 54+775)	Contractor under the supervision of the Engineer
	2.1.4.	Pollution Control				
	2.1.4.1.	Water Pollution				

Environmental Issues		Ref: Clauses	Additional Measures to be Adopted by the Contractor	Location ⁴	Responsibility
	2.1.4.1.1.	Water Pollution from Construction Wastes	<p>Schedule VI - General Standards for Discharge of Environmental Pollutants (Liquid Waste Disposal) - CPCB</p> <p>The Environment (Protection) Rules, 1986 and Water Act, 1974</p> <ul style="list-style-type: none"> The Contractor shall take all precautionary measures to prevent the generated wastewater from entering into streams, water bodies or the irrigation channels arising due to construction activity. Contractor shall avoid construction works close to the streams or water bodies during monsoon. 	<p>Surface water sources/ drains/ Nalahs/ Ponds etc.</p> <p>At locations: Ponds (Ch30+700 and 45+900) Canal crossings: Minor (Ch48+700, 51+050, 55+200, 59+350, (61+600), Major (Ch66+850), Drainages: (Ch34+175, 44+480, 54+775)</p>	Contractor under the supervision of the Engineer
	2.1.4.1.2.	Water Pollution from Fuel, Lubricants and Chemicals	<p>Petroleum Act and Rules and Environment (Protection) Rules, 1986 (Standards for Emission or Discharge of Environmental Pollutants Schedule – I) for Liquid Waste Disposal</p> <p>Clause 111. (Precaution and Safeguarding the Environment)</p> <p>Annexure ‘A’ to Clause 501 (Protection of Environment) - Section 2 water quality</p> <p>Clause 301.3.2 of MoRTH. (Stripping and preservation of top soil)</p> <ul style="list-style-type: none"> Oil interceptors shall be provided at vehicle parking locations, wash down and refuelling areas. When fuel storage and refuelling areas are located on agricultural land or areas supporting vegetation, the top soil shall be stripped, stockpiled and returned after cessation of such storage. 	<p>Surface water sources/ drains/ Nalahs/ Ponds etc.</p> <p>At locations: Ponds (Ch 30+700 and 45+900), Canal crossings: Minor (Ch48+700, 51+050, 55+200, 59+350, (61+600), Major (Ch66+850), Drainages: (Ch34+175, 44+480, 54+775)</p>	Contractor under the supervision of the Engineer
	2.1.4.2.	Air Pollution			
	2.1.4.2.1.	Dust Pollution	<p>Annexure ‘A’ to Clause 501 (Protection of Environment) - Section 3 Air Quality</p> <p>Clause 111.5. of MoRTH. (Hot mix plant and batch mix plant)</p> <ul style="list-style-type: none"> The conditions for pollution control given in the NoC (consent for establish and operate) by the GPCB shall strictly be followed. Air pollution monitoring shall be conducted as per the Environmental Monitoring Plan and results shall be used to identify any additional pollution control measures that require to be adopted. 	<p>Construction area/ site, Construction camps, Materials Loading / unloading facilities</p>	Contractor under the supervision of the Engineer
	2.1.4.2.2.	Emission from Construction Vehicles, Equipment and Machineries	<p>Schedule-I: Standards for Emission suggested by CPCB/ GPCB</p> <ul style="list-style-type: none"> Certificates issued for such contrivances that were obtained from designated/approved authority shall be submitted along with the specified reporting format to the Engineer. The contractor shall maintain a separate file and submit PUC certificates for all vehicles/equipment/machinery that are being used for the project. Monitoring results shall be submitted to Engineer and PIU. 	<p>Construction camps, Materials Loading / unloading facilities</p>	Contractor under the supervision of the Engineer
	2.1.4.3.	Noise Pollution			

Environmental Issues		Ref: Clauses	Additional Measures to be Adopted by the Contractor	Location ⁴	Responsibility
	2.1.4.3.1.	Noise Pollution: Noise from Vehicles, Plants and Equipments	<p>Noise Limits for vehicles (Environment (Protection) Amendment Rules, 2000) and Part 'E', Schedule – VI of Environment (Protection) Rules, 1986.</p> <p>Clause 5A The Noise Pollution (Regulation and Control) Rules, 2000 (sound emitting construction equipments)</p> <p>Clause 201.2 of MoRTH for Idling of temporary trucks</p> <ul style="list-style-type: none"> All plants and equipment used in construction shall strictly conform to the MoEF/ CPCB noise standards. Noisy construction activities (such as crushing, concrete mixing, batching etc.) within 150m of the nearest habitation/ educational institutes/health centres (silence zones) shall be stopped during the night time between 9.00 pm to 6.00 am. Contractor shall provide noise barriers to the suggested locations of identified schools/ Temples/health centres prior to commencement of work. Monitoring shall be carried out at the construction sites as per the monitoring schedule and results shall be submitted to Engineer. Based on the monitoring results, the Engineer, if required, shall recommend any additional noise mitigation measures required to be implemented by the Contractor. 	<p>Sensitive receptors: School (Ch54+000), Hospital (Ch59+050)</p> <p>Sensitive habitations: Vadhavan reservoir (Ch40+000)</p>	Contractor under the supervision of the Engineer
	2.1.4.4.	Safety			
	2.1.4.4.1	Safety Procedures	<p>The Contractor shall:</p> <ul style="list-style-type: none"> Comply with all applicable safety regulations, Take care of the safety of all personnel who are entitled to be on the Site, Use reasonable efforts to keep the site and works clear of unnecessary obstructions so as to avoid danger to personnel, Fencing, lighting, guarding and supervision of the works shall be carried out and provided until completion and taking over .It is necessary to provide any temporary works (including roadways, footways, guards and fences) as necessary, since the execution of these works, shall not raise a concern for the purpose of use and protection of the public and of owners as well as occupiers of adjacent land A construction safety checklist has been included (Appendix 1 Form EM-7) 	All construction sites	Contractor under the supervision of the Engineer
	2.1.4.4.2	Care and supply of Documents	<ul style="list-style-type: none"> The contractor shall prepare, submit and obtain approval from the Engineer for construction of the Safety Management Plan, and the same shall be prepared 14 days prior to commencement of construction works at site. 		Contractor under the supervision of the Engineer
	2.1.4.4.3	Contractors general obligations	<ul style="list-style-type: none"> All design calculations and fabrication drawings for temporary works (such as form-work, staging, centring, scaffolding, specialized construction, handling and launching equipment and the like) material lists for structural fabrication as well as detailed drawings for templates, and anchorage and temporary support details for pre stressing cables as well as bar bending and cutting schedules for reinforcement, etc shall be prepared by the contractor at his own cost and forwarded to the Engineer at least six weeks in advance of the actual constructional requirements. The Engineer will check the same for the contractor's use with amendments. 		Contractor under the supervision of the Engineer

Environmental Issues		Ref: Clauses	Additional Measures to be Adopted by the Contractor	Location ⁴	Responsibility	
	2.1.4.4.4	Personal Safety Measures for Labour, Material handling , Painting etc.	<p>Factory Act, 1948, Factories (Amendment) Act, 1987 (Chapter -5 Safety)</p> <p>Building and Other Construction Workers (Regulation of Employment and Conditions of Services) Act, 1996</p>	<p>Construction Safety Plan shall be prepared by the Contractor during mobilization and approved by Engineer and shall be adhered to by the Contractor throughout the construction period, and shall include provision of:</p> <ul style="list-style-type: none"> • Protective footwear and protective goggles to all workers employed in mixing asphalt materials, cement, lime mortars, concrete etc. • Welders protective eye-shields to the workers engaged in welding works • Protective goggles and clothing to workers engaged in stone breaking activities and workers shall be seated at sufficiently safe intervals • The contractor shall comply with all regulations regarding safe scaffolding, ladders, working platforms, gangway, stairwells, excavations, trenches and safe means of entry and egress. • The contractor shall ensure that no paint containing lead or lead products is used except in the form of paste or readymade paint. • Contractor shall provide facemasks to the workers when paint is applied in the form of spray or a surface having dry lead paint when it is rubbed and scrapped. • The Contractor shall mark 'hard hat' and 'no smoking' and other 'high risk' areas and enforce non-compliance of use of PPE with zero tolerance. 	All construction sites	Contractor under the supervision of the Engineer
	2.1.4.4.5	Health and Safety	<ul style="list-style-type: none"> • The Contractor shall at all times take all reasonable precautions to maintain the health and safety of the contractor's personnel. In collaboration with local health authorities, the contractor shall ensure that medical staff, first aid facilities, sick bay and ambulance service are available at all times at the site. • The contractor shall appoint an accident prevention officer at the site, responsible for maintaining safety and protection against accidents. This person shall be qualified for this responsibility, and shall have the authority to issue instructions and take protective measures to prevent accidents. Throughout the execution of the works, the contractor shall provide whatever is required by this person to exercise this responsibility and authority. • The contractor shall send, to the Engineer, details of any accident as soon as practicable after its occurrence. • The contractor shall maintain records and make reports concerning health, safety and welfare of persons, and damage to property, as the Engineer may reasonably require. 	All construction sites and labour camps	Contractor under the supervision of the Engineer	
	2.1.4.4.6	Traffic Safety & Pedestrian Safety	<p>Clause 112. of MoRTH (Arrangement for traffic during construction)</p> <ul style="list-style-type: none"> • Pedestrian Safety shall be ensured. Pedestrian circulation shall be demarcated prior to start & unsafe areas shall be cordoned off. 	All along the project corridor	Contractor under the supervision of the Engineer	
	2.1.4.4.7	Risk from Electrical Equipment(s)	<p>Factory Act, 1948 – Chapter -5 (Safety) and Factories (Amendment) Act, 1987</p> <ul style="list-style-type: none"> • No material shall be so stacked or placed as to cause danger or inconvenience to any person or the public. • All machines to be used in the construction shall conform to the relevant Indian Standards (IS) codes, shall be free from patent defect, shall be kept in good working order, shall be regularly inspected and properly maintained as per IS provision and to the satisfaction of the Engineer 	All construction equipment	Contractor under the supervision of the Engineer	

Environmental Issues		Ref: Clauses	Additional Measures to be Adopted by the Contractor	Location ⁴	Responsibility	
	2.1.4.4.8	Safety during Road Works	Clause 112.4. of MoRTH (Traffic safety) Clause 112.5. of MoRTH (Maintenance and Diversions) IRC:SP:55 (Road signage and markings)	<ul style="list-style-type: none"> The contractor shall provide adequate signage and markings as per the instruction of the Engineer in the construction zones. 	All along the project corridor and all haul roads	Contractor under the supervision of the Engineer
	2.1.4.4.9	First Aid	Section 36 (First Aid) of Building and the other Construction Workers(Regulation of Employment and Conditions of Service) Act, 1996	<ul style="list-style-type: none"> First aid measures shall be provided in the construction zones and labour camps. 	All construction sites and labour camps	Contractor under the supervision of the Engineer
	2.1.4.5.	Cultural Property				
	2.1.4.5.1.	Chance Found Archaeological Property	Ancient Monuments and Archaeological Sites and Remains Rules 1959 Ancient Monuments and Archaeological Sites and Remains (Amendment and Validation) Act 2010	<ul style="list-style-type: none"> All fossils, coins, articles of value of antiquity, structures and other remains or things of geological or archaeological interest discovered on the site are the property of the Government and shall be dealt as per provisions of the relevant legislation. The contractor shall take reasonable precautions to prevent his workmen or any other persons from removing and damaging any such article or thing. 	Along the project corridor	Contractor under the supervision of the Engineer
	2.2.	Environmental enhancement and special issues				
	2.2.1.	Enhancement measures		<ul style="list-style-type: none"> Landscaping at junctions to improve aesthetics etc. Rehabilitation of cultural and community properties (Appendix 3) 	At suitable locations along the project road	Contractor under the supervision of the Engineer
	2.2.2.	Rehabilitation/ enhancement of Cultural and Religious Properties	Physical Cultural Resources (WB OP/BP 4.11)	<ul style="list-style-type: none"> The architectural elements of the structure shall be conserved/reflected/translated into the design of new structures/ enhancements in accordance with wishes of the community. 		
	2.2.3.	Flora and Chance found Fauna		<ul style="list-style-type: none"> The contractor shall take reasonable precaution to prevent his workmen or any other persons from removing and damaging any flora (plant/vegetation) and fauna (animal) including fishing in any water body and hunting of any animal. If any wild animal is found near the construction site at any point of time, the contractor shall acquaint the Engineer and execute the Engineer's instructions for dealing with the same. The Engineer shall report to the nearby forest office (range office) and shall take appropriate steps/ measures in consultation with the forest officials. 	Along the project road / forest	Contractor under the supervision of the Engineer

Environmental Issues		Ref: Clauses	Additional Measures to be Adopted by the Contractor	Location ⁴	Responsibility
	2.2.4.	Sensitive receptors	<ul style="list-style-type: none"> Sensitive receptors like schools, hospitals are provided with permanent noise barriers prior to the start of work in order to minimize the dust and noise impacts due to vehicle movement (during / post construction). Their effectiveness needs to be checked during operation phase. Construction activities shall be confined within the present available CoI, regular strict monitoring/supervision shall be done to minimize/control air-noise pollution and abatement of dust particles at minimum level possible using well maintained modern machineries. 	Sensitive Receptors at: School at Ch 54+000 and Hospital at Ch59+050	Contractor under the supervision of the Engineer
	2.3.	Contractor Demobilization			
	2.3.1.	Clearing of Construction of Camps & Restoration	<ul style="list-style-type: none"> Contractor to prepare site restoration plans for approval by the Engineer. The plan shall be implemented by the contractor prior to demobilization. On completion of the works, all temporary structures shall be cleared, all rubbish burnt, excreta or other disposal pits or trenches filled in and effectively sealed off and the site left clean and tidy, at the Contractor's expense, to the entire satisfaction of the Engineer. The topsoil removed and conserved earlier shall be spread over the restoration area as per the direction of the Engineer to facilitate the growth of vegetation. Residual topsoil shall be distributed on adjoining/proximate barren/rocky areas as identified by the Engineer in a layer of thickness of 75mm – 150mm. 	All Construction Workers' Camps	Contractor under the supervision of the Engineer
	2.3.2.	Redevelopment of Borrow Areas	<ul style="list-style-type: none"> Redevelopment of borrow areas shall be taken up in accordance with the plans approved by the Engineer 	At all borrow area locations suggested for the project. Vaga village(Ch30+750) Pancholi village (Ch37+500), RHS of Corridor(Ch54+500)	Contractor under the supervision of the Engineer
3. OPERATION STAGE (Activities to be Carried Out by the Contractor/Engineer/PIU)					
	3.1.	Monitoring and Evaluation of Operational Performance of Environmental Mitigation Measures	<ul style="list-style-type: none"> The PIU shall monitor the operational performance of the various mitigation/ enhancement measures carried out as part of the project. Monitoring and performance indicators have been indicated in Environmental Monitoring Plan (Table 4.2). 	All along the project corridor	Contractor under the supervision of the Engineer
	3.2.	Maintenance of Drainage	<ul style="list-style-type: none"> PIU shall ensure that all drains (side drains and all cross drainages) are periodically cleared especially before monsoon season to facilitate the quick passage of rainwater and avoid flooding without damaging the spurs and check dams erected to stabilize the course and flow of all such drainage channels. PIU shall ensure that all the sediment/oil and grease traps set up at the water bodies are cleared once in every three months. 	At locations where bridge works and culverts are proposed. Bridge locations: Ch44+330, 50+900, 56+100, 59+150, 61+500, 62+900, 65+025, 66+800 Culvert locations: Culvert: 23 proposed culverts and 17 existing culverts	Contractor under the supervision of the Engineer

Environmental Issues		Ref: Clauses	Additional Measures to be Adopted by the Contractor	Location ⁴	Responsibility
3.3.	Pollution Monitoring		<ul style="list-style-type: none"> The periodic monitoring of the ambient air quality, noise level, water (both ground and surface water) quality, soil pollution/contamination are to be continued at pre-designated locations as identified in the Environmental Monitoring Plan (Table 4.2) and if necessary, at additional locations for comparative study of pre and post operation data in order to ensure further improvement/modification in similar future works. 	All along the project corridor	Contractor under the supervision of the Engineer
3.4.	Atmospheric Pollution		<ul style="list-style-type: none"> Ambient air concentrations of various pollutants shall be monitored as envisaged in the Environmental Monitoring Plan at pre designated locations to compare the levels with the pre-construction data. Additional data at other location may be collected as per any site specific requirement. 	All along the project corridor	Contractor under the supervision of the Engineer
3.5.	Noise Pollution		<ul style="list-style-type: none"> Noise pollution shall be monitored as per Environmental Monitoring Plan at sensitive locations where pre-construction noise data were collected. The functioning of the noise barriers shall be supervised and monitored for further improvement/replication at other affected points if necessary. Signage near sensitive locations shall be maintained and kept clean. Monitoring the effectiveness of the pollution attenuation measures shall be taken up as per Environmental Monitoring Plan (Table 4.2). 	All along the project corridor	Contractor under the supervision of the Engineer
3.6.	Soil Erosion and Monitoring of Borrow Areas		<ul style="list-style-type: none"> Visual monitoring and inspection of soil erosion at borrow areas, quarries (if closed and rehabilitated), embankments and other places expected to be affected, shall be carried to record and monitor the effectiveness of such structures after the completion of project, so as to evaluate the beneficial effects of each type of activity together with the cost involved. 	Borrow areas: Vaga village(Ch30+750) Pancholi village (Ch37+500), RHS of Corridor(Ch54+500)	Contractor under the supervision of the Engineer
3.7.	Road Safety and Maintenance of Assets		<ul style="list-style-type: none"> No advertisement/hoardings shall be allowed within the Right of Way limits of the project road. Regular maintenance and cleaning of assets such as sign boards, bus stops, drains etc. shall be undertaken. 	All along the project corridor	Contractor under the supervision of the Engineer

4. IMPLEMENTATION ARRANGEMENTS

4.1 ENVIRONMENTAL MONITORING PLAN

22. The monitoring programme is devised to ensure that the envisaged purpose of the project is achieved and results in the desired benefit to the target population. To ensure the effective implementation of the EMP, it is essential that an effective monitoring programme be designed and carried out. Broad objectives of the monitoring programme are:

- To evaluate the performance of mitigation measures proposed in the EMP;
- To suggest improvements in the management plans, if required;
- To satisfy the statutory and community obligations; and,
- To provide feedback on adequacy of Environmental Impact Assessment

4.1.1 Monitoring Indicators

23. The monitoring programme contains monitoring plan for all performance indicators, reporting formats and necessary budgetary provisions. Physical, biological and environmental management components identified as of particular significance in affecting the environment at critical locations have been suggested as Performance Indicators (PIs). The Performance Indicators shall be evaluated under two heads as:

- Environmental condition indicators to determine efficacy of environmental management measures in control of air, noise, water and soil pollution;
- Environmental management indicators to determine compliance with the suggested environmental management measures.

Table 4.1: Environmental Monitoring Indicators

Sr. No.	Indicator	Details	Stage	Responsibility
A Environmental Condition Indicators and Monitoring Plan				
1	Air Quality	The parameters to be monitored, frequency and duration of monitoring as well as the locations to be monitored will be as per the Monitoring Plan prepared (Refer Table 4.2)	Pre-Construction	PIU through DPR Consultants
			Construction	Contractor under the supervision of Engineer/ PIU
			Operation (DL Period)	Contractor under the supervision of Engineer/ PIU
2	Noise Levels		Pre-Construction	PIU through DPR Consultants
			Construction	Contractor under the supervision of Engineer/ PIU
			Operation (DL Period)	Contractor under the supervision of Engineer/ PIU
3	Water Quality	Pre-Construction	PIU through DPR Consultants	
		Construction	Contractor under the supervision of Engineer/ PIU	
4	Soil Quality	Pre-Construction	PIU through DPR Consultants	
		Construction	Contractor under the supervision of Engineer/ PIU	
B Environmental Management Indicators and Monitoring Plan				
1	Tree Cutting	Progress of tree removal marked for cutting is to be reported.	Pre-construction	Forest Department/PIU
2	Construction Camps	Location of construction camps have to be identified and parameters indicative of environment in the area has to be reported.	Pre-construction	Contractor under the supervision of Engineer/ PIU
3	Borrow Areas	Location of borrow areas have to be identified and parameters indicative of environment in the area has to be reported.	Pre-construction	Contractor under the supervision of Engineer/ PIU
4	Rehabilitation of Borrow Areas	Engineer will undertake site visits to verify that all borrow areas have been rehabilitated in line with the landowner's request and to their full satisfaction.	Construction	Contractor under the supervision of Engineer/ PIU

24. For each of the environmental condition indicator, the monitoring plan specifies the parameters to be monitored, location of the monitoring sites (Appendix 2), frequency and duration of monitoring. The monitoring plan also specifies the applicable standards, implementation and supervising responsibilities. The monitoring plan for environmental condition indicators of the project in construction and operation stages is presented in Table 4.2.

Table 4.2: Environmental Monitoring Plan

Attribute	Project Stage	Parameter	Special Guidance	Standards	Frequency	Duration	Location	Implementation
Air	Construction	SO ₂ , NO _x , PM ₁₀ , PM _{2.5} , CO	High volume sampler to be located 50m from the plant in the Downwind direction. Use method specified by CPCB for analysis. Environmental monitoring shall be conducted by NABL aggregated laboratory.	Air (prevention and Control of Pollution) Rules, CPCB, 2009	Three seasons per year	24 hours Sampling	Along the road Hot mix / batching plant	Contractor under the supervision of the Engineer
	Three seasons for one year				Along the road			
Noise	Construction	Noise levels on dB (A) scale	Equivalent noise levels using an integrated noise level meter kept at a distance of 15 from edge of pavement Equivalent noise levels using an integrated noise level meter kept at a distance of 15 from edge of pavement. Environmental monitoring shall be conducted by NABL aggregated laboratory.	MoEF Noise Rules, 2000	Three seasons per year	Leq in dB(A) of day time and night time	Along the road Hot mix / batching plant	Contractor under the supervision of the Engineer
	Three seasons for one year				Along the road			
Water	Construction	All essential characteristics and some of desirable characteristics as decided by the Environmental Specialist of the SC and PIU	Grab sample collected from source and Analyse as per Standard Methods for Examination of Water and Wastewater. Environmental monitoring shall be conducted by NABL aggregated laboratory.	Indian Standards for Inland Surface Waters (IS: 2296, 1982)	Three seasons per year	Grab Sampling	Along the road Surface water sources	Contractor under the supervision of the Engineer
Soil	Construction	Monitoring of Pb, SAR and Oil & Grease	Sample of soil collected to acidified and analysed using absorption Spectrophotometer. Environmental monitoring shall be conducted by NABL aggregated laboratory.	Threshold for each contaminant set by IRIS database of USEPA until national standards are promulgated	Once in a year	Grab Sampling	Along the road Hot mix / batching plant	Contractor under the supervision of the Engineer
Borrow area	Pre-construction	Suitability of the material as per IS 2720	-	IS 2720	Once	Once	Borrow area location	Contractor under the supervision of the Engineer
Rehabilitation of Borrow Areas	Construction	As per Guidelines	Visual Observation	-	Once in a month	-		
HIV/ AIDS Prevention Measures	Construction	Awareness campaign	-	-	Annual	-	Construction and Labour Camp sites	Contractor under the supervision of the Engineer/ R&BD/PIU
		HIV/ AIDS Screening of construction personnel's			Within 3 months of mobilisation and every quarter during construction			
		IEC materials distribution			Quarterly			
		Condom Distribution			Once a month			

⁵ Parameters to be monitored for Operation stage is same as Construction stage

4.2 REPORTING SYSTEM

25. Reporting system for the suggested monitoring program operates at two levels as:

- Reporting for environmental management (EM) indicators (except tree cutting indicator)
- Reporting for environmental condition (EC) indicators at the PIU level

26. Contractor and Engineer operate the reporting system for environmental management indicators (except tree cutting). The Environmental Management Unit of PIU will operate the reporting system for environmental management tree cutting indicator and environmental condition indicators. The PIU will set the targets for each activity envisaged in the EMP beforehand and all reports will be against these targets.

27. Contractor will report to the Engineer on the progress of the implementation of environmental management measures as per the EMP. The Engineer will in turn report to the PIU on a quarterly basis. Along with these reports, EMU shall report progress of tree cutting, compensatory plantation and survival rate as per the monitoring plan. Reporting formats have been prepared, which will form the basis of monitoring, by the Engineer and/or the Environmental Cell as required and presented as Appendix 1.

Table 4.3: Summary details of Reporting

Format No.	Item	Stage	Contractor	Engineer		Project Implementation Unit (PIU)
			Implementation & Reporting to Engineer	Supervision	Reporting to PIU	Oversee / Field Compliance Monitoring
EM 1	Identification of Disposal Locations	Pre-Construction	One Time	One Time	One Time	One Time
EM 2	Setting up of Construction Camp	Pre-Construction	One Time	One Time	One Time	One Time
EM 3	Borrow Area Identification	Pre-Construction	One Time	One Time	One Time	One Time
EM 4	Tree Cutting	Pre-Construction	-	-	-	Monthly
EM 5	Top Soil Monitoring	Construction	Quarterly	Continuous	Quarterly	Quarterly
EM 6	Status Regarding Rehabilitation of Borrow Areas	Construction	-	-	-	Half Yearly
EM 7	Construction Safety	Construction	Quarterly	Continuous	Quarterly	Quarterly
EC 1	Pollution Monitoring	Construction	As Per Monitoring Plan	Quarterly	Quarterly	Quarterly
EC 2	Pollution Monitoring	Post Construction (DL Period)	As Per Monitoring Plan	Quarterly	Quarterly	Quarterly

28. In addition to these formats, to ensure that the environmental provisions are included at every activity of the implementation by the contractor, it is suggested that the approval of the environmental personnel of the engineer is required in the request for application to proceed or other similar reporting formats used by the contractor. These will not only ensure that the environmental provisions are addressed but also link the satisfactory compliance to environmental procedures prior to approval of the Interim Payment Certificate (IPC) by the Engineer. The activities by the contractor that can impact the environment will be identified based on discussions between the Environmental Specialist of the PIU, team leader of the Engineer and the Environmental personnel of the Engineer. The decisions will be communicated to the contractor prior to the start of the construction activities.

29. The contractor shall take all reasonable steps to protect the environment on and off the Site and to avoid damage or nuisance to persons or to property of the public or others resulting from pollution, noise or other causes arising as a consequence of his methods of operation.

4.3 CLAUSE FOR NONCONFORMITY TO EMP - PROTECTION OF THE ENVIRONMENT

30. The Contractor shall implement all mitigation measures for which responsibility is assigned to him as stipulated in the EMP Report. Any lapse in implementing the same will attract the damage clause as detailed below:

1. All lapse in obtaining clearances / permissions under statutory regulations and violations of any regulations with regard to eco-sensitive areas shall be treated as a major lapse.
2. Any complaints of public, within the scope of the Contractor, formally registered with the CSC, R & BD or with the GoG and communicated to the Contractor, which is not properly addressed within the time period intimated by the CSC / R & BD, GoG shall be treated as a major lapse.
3. Non-conformity to any of the mitigation measures stipulated in the EMP Report (other than stated above) shall be considered as a minor lapse.
4. On observing any lapses, CSC shall issue a notice to the Contractor, to rectify the same.
5. Any minor lapse for which notice was issued and not rectified, first and second reminders shall be given after ten days from the original notice date and first reminder date respectively. Any minor lapse, which is not rectified, shall be treated as a major lapse from the date of issuing the second reminder.
6. If a major lapse is not rectified upon receiving the notice CSC shall invoke reduction, in the subsequent interim payment certificate.
7. For major lapses, 10% of the interim payment certificate will be withheld, subject to a maximum limit of about 0.5% of the contract value.
8. If the lapse is not rectified within one month after withholding the payment, the amount withheld shall be forfeited.

4.4 INSTITUTIONAL SETUP

31. During implementation of project R&BD, Supervision Consultant, SC (if any) and Contractor will be responsible for ensuring that the environmental commitments made to regulatory agencies, lending agencies and other stakeholders during the EIA process are met. To execute EMP is a cumulative responsibility of all three parties involved, indicative responsibility mechanism has been presented in Table 4.4, as developed for upgradation projects.

Table 4.4: Institutional Responsibilities

System	Designation	Responsibilities
Coordinating/Facilitating Agency	Chief Engineer (WB), R&BD	<ul style="list-style-type: none"> • Overview of the project implementation • Ensure timely budget for the EMP • Coordination with different state level committee, to obtain Regulatory Clearances • Participate in state level meetings • Monthly review of the progress.
	Superintending Engineer PIU	<ul style="list-style-type: none"> • Overall responsible for EMP implementation • Reporting to various stakeholders (World Bank, Regulatory bodies) on status of EMP implementation • Coordination with PIU Staff (Environmental officer). • Responsible for obtaining Regulatory Clearances • Review of the progress made by contractors • Ensure that BOQ items mentioned in EMP are executed as per Contract provisions.
	Environment and R&R Specialist (PIU)	<ul style="list-style-type: none"> • Assisting SE in overall implementation of EMP • Review of periodic reports on EMP implementation and advising SE in taking corrective measure. • Conducting periodic field inspection of EMP implementation • Assisting SE to reporting various stakeholders (World Bank, Regulatory bodies) on status of EMP implementation • Preparing environmental training program and conducting the same for field officers and engineers of contractor
Implementing/Monitoring Agency	Engineer (Supervision consultant SC)	<ul style="list-style-type: none"> • Responsible for supervision of effective implementation of EMP measures by the contractor • Review progress reports and periodic reporting to PIU about the status of EMP implementation • Work in close coordination with ERRS (PIU) and contractor
	RAP implementation NGO	<ul style="list-style-type: none"> • Conducting awareness campaign for all construction personnel (including labourers, supervisors, engineers and consultants) about HIV/AIDS/STDs in the construction and labour camps. • Facilitating the medical testing/ routine check-up for labours as suggested in the HPP
Contractor	Environmental Manager of Contractor	<ul style="list-style-type: none"> • Responsible for ensuring the implementation of EMPs as per provision in the document. • Directly reporting to the Project Manager of the Contractor • Discussing various environmental/social issues and environmental/social mitigation, enhancement and monitoring actions with all concerned directly or indirectly • Assisting his project manager to ensure social and environmentally sound and safe construction practices • Conducting periodic environmental and safety training for contractor's engineers, supervisors and workers along with sensitization on social issues that may be arising during the construction stage of the project • Assisting the PIU on various environmental monitoring and control activities including pollution monitoring; and • Preparing and submitting monthly reports to PIU on status of implementation safeguard measures

4.5 GOOD ENVIRONMENTAL CONSTRUCTION GUIDELINES

32. Comprehensive environmental construction guidelines has been prepared and presented in the Appendix 4. The purpose of the guideline is to guide the contractor and the project proponent to mitigate the environmental issues that are like to arise during the project construction and operation.

Table 4.5: Guideline for Good Environmental Practices

Guidelines	Activities
Guideline-1	Site Preparation
Guideline-2	Construction and Labour Camps

Guidelines	Activities
Guideline-3	Borrow Areas
Guideline-4	Topsoil Salvage, Storage and Replacement
Guideline-5	Quarry Management
Guideline-6	Water for Construction
Guideline-7	Slope Stability and Erosion Control
Guideline-8	Waste Management and Debris Disposal
Guideline-9	Water Bodies
Guideline-10	Drainage
Guideline-11	Construction Plants & Equipment Management
Guideline-12	Labour and Worker's Health and Safety
Guideline-13	Cultural Properties
Guideline-14	Forests and Other Natural Habitats
Guideline-15	Air and Noise Pollution
Guideline-16	Environmental Monitoring

5. ENVIRONMENTAL MANAGEMENT BUDGET

33. Budgetary estimates for environmental management in the project include all items envisaged as part of the EMP. The environment budget includes provisions for various environmental management measures (other than measures considered under good engineering practices) and the environmental monitoring costs. Budgetary provisions for the project are presented in Table 5.1. Bill of Quantities is given in Appendix 5.

Table 5.1: Budgetary Provisions for Environmental Management Measures

S. No.	Item	Unit	Rate (in INR)	Quantity	Cost (in INR)
A	CONSTRUCTION PHASE				
1	Site Clearance				
1.1	Disposal of unserviceable as well serviceable material with all leads and lifts beyond the ROW	Cum	Bill no 2, item no 2.02		
1.2	The 30 cm top layer of disposal pit shall be provided with good earth, suitable for development of vegetation/plantation. All work shall be carried out as per specifications 301.3.2 of MoRTH and approval of the Engineer in Charge	Cum	Provision shall be made by the contractor		
1.3	Regular water sprinkling (at least 4 times) per day at all construction sites for suppression of visible dust levels. <i>Note: This item is to be operated after the completion of earthwork to suppress the visible dust levels. Cost of watering during compaction of earthwork is deemed to be already covered under civil works.</i>	Km	Provision shall be made by the contractor		
2	Construction near water bodies				
2.1	Construction of silt traps at the discharge points of channels into to fresh water bodies across the project road as indicated in the Clause 111.4 and 111.18	m	Provision shall be made by the contractor		
2.2	Providing Oil Interceptors at the fuel/oil storage camps or Construction camps.	nos	Provision shall be made by the contractor		
2.3	Providing and Construction of Rain water Harvesting complete as per drawings and Technical Specification section 300, 1300, 1500, 1700 or as directed by the Engineer.	nos	Bill no.8, item 8.25		
3	Worker Safety				
3.1	Providing Personal Protective Equipment to the labours during the construction phase of the project	nos	Provision shall be made by the contractor		
4	Monitoring of Environmental Attributes during Construction Activity				
4.1	Air Quality				
4.1.1	Monitoring of Air Quality near Hot mix plants	No. of Samples	7500.00	18.00	1,35,000.00
4.1.2	Monitoring of Air Quality at Critical Locations	No. of Samples	7500.00	18.00	1,35,000.00
4.2	Noise Levels				
4.2.1	Monitoring of Noise Level at Equipment Yards	No. of Samples	3000.00	18.00	54,000.00
4.2.2	Monitoring of Noise Levels at Critical Locations	No. of Samples	3000.00	18.00	54,000.00
4.3	Water Quality	No. of Samples	6000.00	24.00	1,44,000.00

S. No.	Item	Unit	Rate (in INR)	Quantity	Cost (in INR)
4.4	Soil Quality	No. of Samples	6000.00	8.00	48,000.00
5	<i>Enhancement Measures of Cultural Properties</i>				
5.1	Hanuman Temple (32+800)				1,33,682.00
6	<i>HIV/ AIDS Prevention measures</i>				
6.1	IEC materials - printing, publishing		3000.00	24.00	72,000.00
6.2	Healthcare clinic		30000.00	8.00	2,40,000.00
6.3	Condom vending machines		15000.00	3.00	45,000.00
6.4	condom supplies		5000.00	24.00	1,20,000.00
6.5	Testing		1500.00	500.00	7,50,000.00
6.6	Signages and hoardings		15000.00	15.00	2,25,000.00
	Environmental Budget During Construction Phase				21,55,682.00
B	OPERATION PHASE				
1	Monitoring of Air Quality at Critical Locations	No. of Samples	7500.00	18.00	1,35,000.00
2	Monitoring of Noise Levels at Critical Locations	No. of Samples	3000.00	18.00	54,000.00
	Environmental Budget During Operation Phase				1,89,000.00
	Sub Total (A+B)				23,44,682.00
	Grand Total INR. (Environmental Budget Exclusive of Cost of Measures Included Under Good Engineering Practices, A+B+3% contingency)				24,15,023.00

Appendix - 1: Environmental Monitoring Formats

Format EM1: Selection of disposal site locations

From _____ To _____

(Give chainage and nearest settlements from both ends)

Criteria on which information for each site is to be collected	Site 1	Site 2	Site 3	Site 4
Area covered (m ²)				
Total Material that can be dumped within the site (m ³)				
Depth to which disposal is feasible (m)				
Distance of nearest watercourse (m)				
Nearest Settlement (m)				
Date/s of Community Consultation/s				
Whether the community is agreeable to siting of dumping site (Y/N)				
Date of Permission from Village Council President(VCP)				
Proposed future use of the Site				

Selected Site (tick any one column only)

Certified that the above information is correct to the best of my knowledge and belief.

Contractor

Signed:

Name & Designation:

Date:

Recommendation on the suitability of the site

Decision Taken (tick one):

Approved/Not Approved

Engineer – In-Charge

Signed:

Name and Designation of Deciding Authority

Date:

Enclosures

(Tick as appropriate)

- 1 Maps of each location
- 2 Photographs
- a Each disposal location
- b Each community consultation
- 3 Photocopies of permissions from VCPs

Format EM2: Construction Camp and Storage Area

Construction Stage: Report - Date____ Month_____ Year_____

(Site Layout of Construction camp and working drawings of dwelling units with allied facilities to be attached with format)
Format to be submitted before target date (decided by PIU) of establishing camps

Location of Camp (km_____)

Sl. No	Item	Unit	Details	Remarks
1	Detail of item camp			
a	Size of Camp	mxm		
b	Area of Camp	sq.m		
c	Distance from Nearest Settlement			
d	Distance from Nearest Water Source	Type/Size/Capacity/Present Use/Ownership		
e	Date of camp being operational dd/mm/yy			
f	Present land use			
g	No other trees with girth > 0.3m.			
h	Details of Storage area(Availability of impervious surface)	mxm		
i	Availability of separate waste disposal from storage area	Cum		
2	Details of top soil stacking			
a	Quantity of top soil removed	Cum		
b	Detail of storage of topsoil	Describe stacking arrangement		
3	Details of workforce			
a	Total No of Labourers	nos		
b	Total no of Male Workers	nos		
c	No of Male Workers below 18 years of age	nos		
d	Total No of Female Workers	nos		
e	No of Female workers below 18 years of age	nos		
f	No of children	nos		
4	Details of dwelling units			
a	No of dwellings/huts	nos		
b	Minimum Size of Dwelling	mxm		
c	No of openings per dwelling	nos		
d	Minimum size of opening	mxm		
e	Walls	specifications		
f	Roofing	specifications		
g	Flooring	specifications		
h	Drinking Water Tank	specifications		
i	Capacity of Drinking water Tank	cum		
j	Size of Drinking Water Tank	mxmxm		
k	Total no of WC	nos		
l	No of Wcs for female workers	nos		
m	Minimum Size of WC	mxm		
n	Total No of Bathrooms for female workers	nos		
o	Size of septic tank for WC/Baths	mxmxm		
p	Capacity of Water Tank for WCs/ Bathrooms and general purpose			
q	Fencing around camp	Y/N		
5	Details of facilities			
a	Availability of security guard 24 hrs a day	Yes/No		
b	Details of First Aid Facility	Yes/No		
c	Availability of Day Care Centre	Yes/No		
d	Availability of dust bins (capacity 60 ltr)	nos		

Certified that the furnished information is correct the quality of work is as per god practice and all relevant information as required is attached

Contractor

Engineer – In -Charge

Format EM3: Reporting for Borrow Areas

Construction Stage Report: Date ____ Month _____ Year _____ Site Layout of Borrow Area and Proposed Borrow Area Redevelopment Plan to be attached with format Format to be submitted before target date as (decided by PIU) for establishing Borrow Areas Borrow Area No. BA _____
Location of Borrow Area (Km _____)

Sl. No	Item	Unit	Details	Remarks by CSC, if any
1	Details of Borrow Area			
a	Date of Borrow Area becoming operational dd/mm/yy			
b	Current Landuse			
c	Distance from Nearest Settlement	Km		
d	No of settlements within 200m of Haul Road	No.		
e	No of settlements within 500m of Borrow Area	No.		
f	Total Capacity	cum		
g	No of Trees with girth more than 0.3 m	No.		
h	Length of Haul Road	km		
i	Width of Haul road	m		
j	Type of Haul Road	metal/dirt		
k	Size of Borrow Area	sqkm		
l	Area of Borrow Area	km x km		
m	Quantity Available	cum		
n	Distance of Nearest Water Source	Type/Size/Capacity/Present Use/Ownership		
o	Quantity of top soil removed	cum		
p	Detail of storage of topsoil			
q	Daily/occasional use of the Borrow Area by the community, if any	-		
r	Probable reuse of Borrow pit-ask community	-		
s	Drainage channels/slope/characteristics of the area	-		
2	Enhancement Elements			
a	Quantity of top soil removed	sq.m		
b	Detail of storage of topsoil	sq.m		
c	Adjoining land use/Natural elements			
d	Near by catchment for storing water			
e	Erosion Control Programme			
f	Preventive measures for			
i	Leaching			
ii	Mosquito Breeding			
iii	Water run-off/contamination			
iv	Any other environmental degradation			
3	Details of workforce			
a	Total No of Labourers	No.		
b	Total no of Male Workers	No.		
c	No of Male Workers below 18 years of age	No.		
d	Total No of Female Workers	No.		
e	No of Female workers below 18 years of age	No.		
4	Details of redevelopment, Plan to be enclosed			

Certified that the furnished information is correct the quality of work is as per good practice and all relevant information as required is attached

Contractor

Engineer – In -Charge

Format EM4: Tree Felling

S.No	Links	Physical Target				Completion Target		
		Total	Target	Target Achieved	% of task completed	Target Date	Date of Completion if task completed	Reason for Delay if any
		Unit						
1		nos						
2		nos						
3		nos						
4		nos						

Contractor

Engineer – In -Charge

EM 5 Topsoil Conservation Monitoring

Contract _____

Report No. _____

Date _____

Location (Chainage)	Original Use of Topsoil removed	Measures for preventing spillage of topsoil on Haul Roads(Earthen/ Metalled)	Present Method of Storage	Anticipated period of Storage (Months)	Distance of nearest Water course (m)	Present Slope of Pile (V: H)	Whether silt fencing provided?	Is any other covering / measure provided? If yes, what is it?	Improvements required	Extent of Compliance as on date of report

Certified that the above is true.

Signed _____

Contractor

Verified

Signed _____

Engineer – In-charge

EM 6 Redevelopment of Borrow Areas

Operation Stage: Report: Date ____ Month____ Year____

To be monitored by PIU during operation period

Details of remarks to be appended wherever necessary.

Sl. No	Activity	Particulars	Drawbacks Identified			Improvements Required		
			Construction	Financial	Others (Ask Community)	Technical	Financial	Remarks/ Suggestions
1	Details of Borrow area and Surrounding Landuse							
2	End use of the borrow area							
3	Whether rehabilitation has been carried out in line with owners request							
4	Erosion Control Measures							
5	Number of trees planted							
6	Reuse of topsoil							
7	Preventive measures taken for -Mosquito Breeding -Water runoff/contamination -Other Environmental Degradation							
8	Any problems faced by owner							
9	Any problems faced by the local community							
10	If it has been developed as a fish pond,							
a	Details of available catchment for storing water							
b	Economic Benefits/Utility							
11	If it has been developed as an orchard							
a	Details of suitability of soil and water.							
B	Type of Plantation							
c	Economic Benefits/Utility							
12	Any Other End use							
a	Particulars							
b	Economic Benefits/Utility							

Contractor

Engineer – In -Charge

EM 7 Checklist for Construction Safety

Sl. No.	Safety Issues	Yes	No	Non compliance	Corrective Action	Penalty	Remarks
Safety during Construction Stage							
1	Appointment of qualified Construction safety officers						
2	Approval for Construction Safety Management Plan by the Engineer.						
3	Approval for Traffic Management/control Plan in accordance with IRC: SP: 55-2001						
4	Maintenance of the existing road stretches handed over to the Contractor.						
5	Provision of Temporary Traffic Barriers/Barricades/caution tapes in construction zones						
6	Provision of traffic sign boards						
7	Provision for flags and warning lights						
8	Provision of metal drum/empty bitumen drum delineator, painted in circumferential strips of alternate black and white 100mm wide 2 coats fitted with reflectors 3 Nos of 7.5cm diameter						
9	Providing plastic crash barrier						
10	Provision of adequate staging, form work and access (ladders with handrail) for works at a height of more than 3.0 m						
11	Provision of adequate shoring / bracing / barricading / lighting for all deep excavations of more than 3.0 m depth.						
12	Demarcations (fencing, guarding and watching) at construction sites						
13	Provision for sufficient lighting especially for night time work						
14	Arrangements for controlled access and entry to Construction zones						
15	Safety arrangements for Road users / Pedestrians						
16	Arrangements for detouring traffic to alternate facilities						
17	Regular Inspection of Work Zone Traffic Control Devices by authorized contractor personnel						
18	Construction Workers safety - Provision of personnel protective equipments						
19	A. Helmets						
	B. Safety Shoe						
	C. Dust masks						
	D. Hand Gloves						
	E. Safety Belts						
	F. Reflective Jackets						
	G. Earplugs for labour						
20	Workers employed on bituminous works, stone crushers, concrete batching plants etc. provided with protective goggles, gloves, gumboots etc.						

21	Workers engaged in welding work shall be provided with welder protective shields						
22	All vehicles are provided with reverse horns.						
23	All scaffolds, ladders and other safety devices shall be maintained in as safe and sound condition						
24	Regular healthcheckup for labour/ Contractor's personnel						
25	Ensuring the sanitary conditions and all waste disposal procedures & methods in the camps.						
26	The Contractor shall provide adequate circuit for traffic flow around construction areas, control speed of construction vehicles through road safety and training of drivers, provide adequate signage, barriers and flag persons for traffic control						
27	Provision for insurance coverage to the contractor's personnel						

Contractor

Engineer – In -Charge

Format EC1: Target Sheet for Pollution Monitoring

Construction Stage: Report - Date_____ Month_____ Year_____

(Locations at which monitoring to be conducted as per EMP)

Sl. No	Chainage	Details of Location	Duration of Monitoring	Instruments Used	Completion Target		Reason for Delay if any
					Target Date	Date of Completion if task completed	
Air Monitoring							
1							
2							
3							
4							
5							
Water Monitoring							
1							
2							
3							
4							
5							
Noise Monitoring							
1							
2							
3							
4							
5							

Certified that the Pollution Monitoring has been conducted at all the locations specified in the EMP

Contractor

Engineer – In -Charge

Format EC 2: Target Sheet for Pollution Monitoring

Operation Stage: Report - Date _____ Month _____ Year _____

(Locations at which monitoring to be conducted)

Sl. No	Chainage	Details of Location	Duration of Monitoring	Instruments Used	Completion Target		Reason for Delay if any
					Target Date	Date of Completion if task completed	
Air Monitoring							
1							
2							
3							
4							
5							
Water Monitoring							
1							
2							
3							
4							
5							
Noise Monitoring							
1							
2							
3							
4							
5							

Certified that the Pollution Monitoring has been conducted at all the locations specified in the EMP

Contractor

Engineer – In -Charge

Appendix - 2: Environmental Monitoring Location

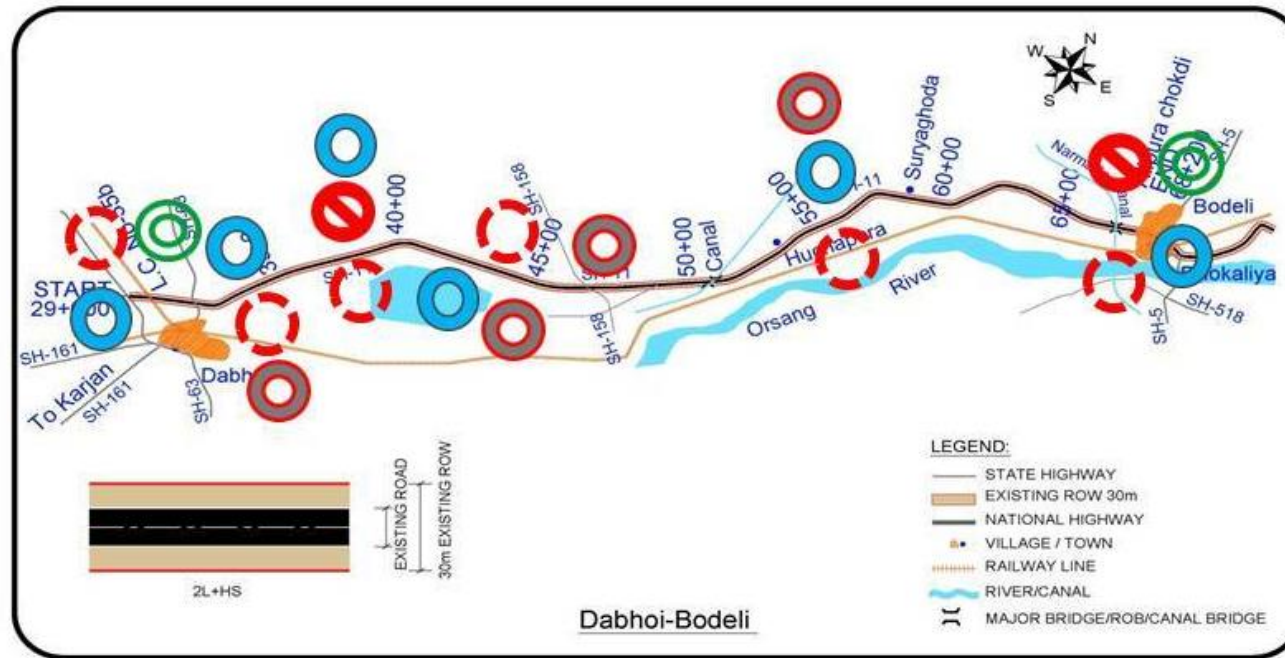

Legend

- Air quality
- Surface Water quality
- Noise quality
- Ground Water quality
- Soil quality

Monitoring Locations

Env. Parameters	Corridor Chainages
Air Quality	29+540, 34+000, 39+500, 44+000, 56+000, 68+400
Water Quality	32+000, 39+500, 67+000, 68+000
Noise Quality	29+530, 34+500, 39+500, 44+000, 56+000, 68+400
Soil Monitoring	34+500, 44+000, 46+700, , 56+000

APPENDIX 3:
ENHANCEMENT MEASURES

SPECIAL NOTES:

- THE CONSULTATION INDICATED THAT THE TEMPLE IS 20 YEARS OLD AND CONSIDERED AUSPICIOUS BY THE COMMUNITY.
- THE TEMPLE IS AT 25 M FROM THE CENTRE OF THE ROAD AND IS A MAJOR NODE OR THE COMMUNITY GATHERING SPACE OF THE SURROUNDING SETTLEMENTS.
- A PAVED PATHWAY, SITTING BENCHES, SHOE RACK AND SOME TREES ARE PROVIDED AS SUGGESTED BY THE COMMUNITY. SPACE IS ALSO CREATED FOR ROAD SIDE PARKING AS SUGGESTED BY THE COMMUNITY.

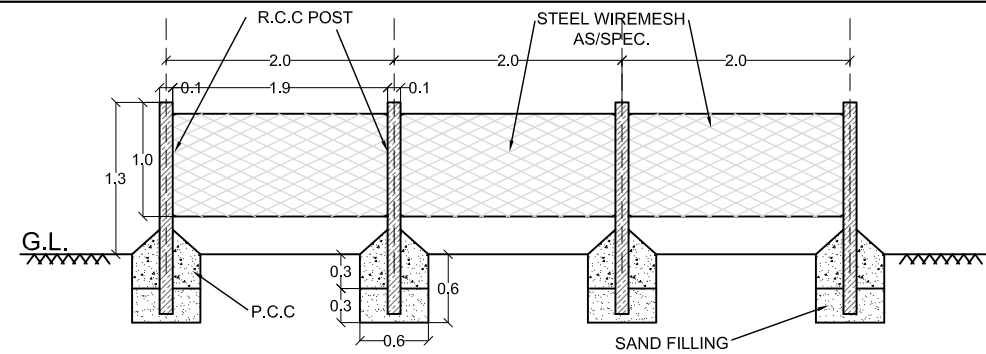

CHAIN FENCING AS PER DESIGN
SCALE: NTS

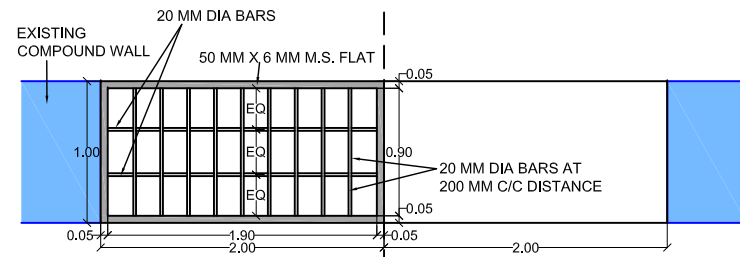

PROPOSED GATE AS PER DESIGN
SCALE: NTS

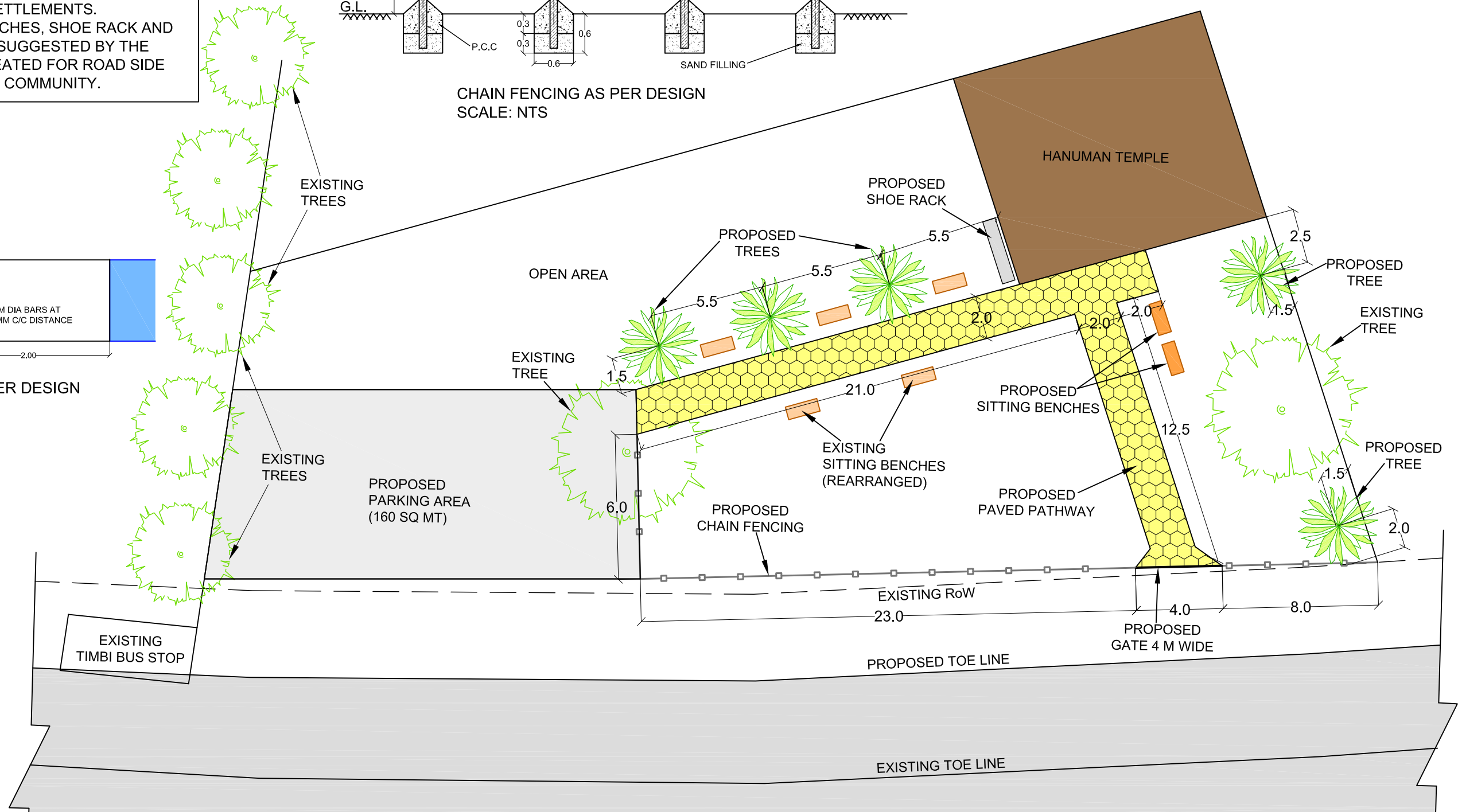

- NOTES:**
- DIMENSIONS ARE IN M UNLESS OTHERWISE SPECIFIED.
 - SPECIFIC CHANGES IF ANY, TO BE MADE ONLY ON APPROVAL OF SUPERVISION CONSULTANT.

Drawing No.	6.20
Drawing	Proposed Enhancement
Kms.	32+800
Scale	1:200

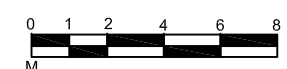

ENHANCEMENT FOR STATE HIGHWAY 11 (DABOI TO BODELI)						
Designed By:	Drawn By:	Checked By:	Approved By:	Date:		
Ar. Ashish Batra	Ar. Ashish Batra	k.Pushpanathan	R. Vishvnathan	June 2012		

GUJARAT STATE HIGHWAYS PROJECT (GSHP-II)

LEA Associates South Asia Pvt. Ltd.
 B-1/E-27, IInd Floor, Mohan Cooperative Industrial Estate,
 Mathura Road, New Delhi-110044
 91-011-6973950-55

APPENDIX – 4: Guidelines for Environmental Management

GUIDELINE-1: SITE PREPARATION

1. GENERAL

The preparation of site for construction involves: (i) clearing of land required for construction; and (ii) management of activities such as traffic during construction. These activities have been detailed out for road construction activities separately.

2. ROAD CONSTRUCTION

2.2 Site Preparation Activities

After obtaining the consent of the community on the alignment, the Project Implementation Unit (PIU) of the Divisional Office shall be responsible to stake out the alignment by establishing working benchmarks on ground. It shall be the responsibility of the PIU to take over the possession of the proposed RoW and hand over the land width required clear of all encumbrances to the Contractor. Activities pertaining to the clearance of land and relocation of utilities need to be initiated by the PIU well in advance to avoid any delays in handing over of site to the Contractor. Assistance of the Revenue Department shall be sought in accomplishing the task. To summarize, the PIU's responsibilities before handing over the site to the contractor include:

- Clearance of encroachments within proposed RoW;
- Initiation of process for legal transfer of land title;
- Alignment modification or Relocation of common property resources in consultation with the local community;
- Alignment modification or Relocation of utilities in consultation with the various government departments; and
- Obtain clearances required from government agencies for
 - Cutting of trees; and
 - Land Diversion of forestlands, etc.

2.2 Site Preparation Activities by the Contractor

Site preparation shall involve formation of the road base wherein it is ready for construction of protective/drainage works, carriageway, shoulders, parapets and other road furniture. The PIU shall transfer the land for civil works to the Contractor after peg marking of the alignment.

The Contractor shall verify the benchmarks soon after taking possession of the site. The Contractor, prior to initiation of site preparation activities, shall highlight any deviations/discrepancies in these benchmarks to the Engineer - Incharge in writing. The contractor shall submit the schedules and methods of operations for various items during the construction operations to the Engineer - Incharge for approval. The Contractor shall commence operations at site only after the approval of the schedules by the Engineer - Incharge.

The activities to be undertaken by the contractor during the clearing and grubbing of the site are as follows:

The clearance of site shall involve the removal of all materials such as trees, bushes, shrubs, stumps, roots, grass, weeds, part of topsoil and rubbish. Towards this end, the Contractor shall adopt the following measures: (i) Limiting the surface area of erodible earth material exposed by clearing and grubbing; (ii) Conservation of top soil and stock piling as per the measures suggested as part of **Guideline 4**, "Top Soil Salvage Storage and Replacement"; and (iii) Carry out necessary backfilling of pits resulting from uprooting of trees and stumps with excavated or approved materials to the required compaction conforming to the surrounding area.

To minimize the adverse impact on vegetation, only ground cover/shrubs that impinge directly on the permanent works shall be removed. Cutting of trees and vegetation outside the working area shall be

avoided under all circumstances. In case the alignment passes through forest areas, The Forest Ranger shall be consulted for identification of presence of any rare/endangered species within the proposed road way. Protection of such species if found shall be as per the directions of the Forest Department.

The locations for disposal of grubbing waste shall be finalized prior to the start of the works on any particular section of the road. The selection of the site shall be approved by the Engineer – in - charge. The criteria for disposal of wastes shall be in accordance with the measures given in Guideline on, “Waste Management and Debris Disposal” (**Guideline 8**).

In locations where erosion or sedimentation is likely to be a problem, clearing and grubbing operations should be so scheduled and performed that grading operations and permanent erosion and sedimentation control features can follow immediately, if the project conditions permit.

Dismantling of CD structures and culverts shall be carried out in a manner as not to damage the remaining required portion of structures and other surrounding properties. The disposal of wastes shall be in accordance with the provisions given in **Guideline 8**, “Waste Management and Debris Disposal”. The following precautions shall be adopted: (i) The waste generated shall not be disposed off in watercourses, to avoid hindrance to the flow, and (ii) All necessary measures shall be taken while working close to cross drainage channels to prevent earthwork, stonework as well as the method of operation from impeding cross drainage at rivers, streams, water canals and existing irrigation and drainage systems.

The designated sites duly approved by Implementing Agency shall be cleared of its existing cover for setting up of the construction sites, camps and related infrastructure facilities, borrow areas and other locations identified for temporary use during construction. The contractor shall comply with all safety requirements in consideration as specified in the **Guideline 12** on, “Labour & Worker’s Health and Safety”. Before initiation of site preparation activities along these lands to be used temporarily during construction, it shall be the responsibility of the Contractor to submit and obtain approval of the site redevelopment plan from the implementing agency. The letter/contract agreement between the owner(s) of the land parcel for temporary usage shall include site redevelopment to its original status. The guidelines for the same are furnished in the Guideline on, “Construction Plants & Equipment Management”; guideline, “Construction and Labour Camps”; and “Borrow areas”.

2.2 Traffic management during construction

Traffic management during construction is an activity specific to the contractors. Contractors must ensure a reasonably smooth flow of traffic during construction. The following are the general principles to be followed for traffic management during construction:

- Partial pavement construction **over long lengths will not be permitted**. The contractor should concentrate his activities over sections such that he can complete continuous fronts of up to a maximum of 1 km before starting the adjacent front. The contractor may open more than one continuous 1 km front provided that he has the separate resources to do so. The resources working on a 1 km front may not be shifted to another front until no longer required on that front.
- The construction activities should be staggered over sub-sections to the extent that the use of plant and equipment is optimized to maximum efficiency and to avoid idling. For road widening operations, excavation **adjacent to the existing road shall not be permitted on both titles simultaneously**. Earthworks must be completed to the level of the existing road before excavation work on the opposite side will be permitted.
- The construction operations taking place on a particular front must be managed efficiently such that delays between successive pavement layers are minimized.
- Before the start of the monsoon season (June) the contractor shall ensure that the pavement over any front is complete, full width, at least upto Dense Bituminous Macadam, DBM level, but preferably with Asphaltic Concrete, AC wearing course. The contractor **should not start any sections of pavement that he cannot complete by the start of the monsoon season**.
- In the absence of permanent facilities, temporary drainage and erosion control measures, as required by the Specifications, are to be implemented prior to the onset of the monsoon.

In cases where separate traffic diversions are not essential or cost effective the construction methodology

should be in accordance with the guidelines following:

On a 1km section, the pavement construction (except new alignments) should be limited to 500m sub-sections with a minimum of 1 to 1.5 km between successive sub-sections to ease traffic management and safety issues. The earthworks in the widening portions are not limited in, this respect. Excavation on both sides of the existing, road over the same sub-section simultaneously shall not be permitted for reasons of safety to the traffic, particularly at night.

Sub-sections longer than 500 m may be authorized by the Engineer if two-way traffic flow can be comfortably managed and the Contractor **can demonstrate his ability to maintain dust control, proper road edge delineation, proper signage and traffic control.** Where single file traffic is permitted ('only applicable to final wearing course operations), the sub-sections shall be reduced to a maximum length whereby safe traffic regulation can be physically managed. Single file traffic may not be permitted at certain locations or times of the day when traffic volumes are such that excessive congestion shall occur.

GUIDELINE-2: CONSTRUCTION AND LABOUR CAMPS

1. INTRODUCTION

The scope of this guideline pertains to the siting, development, management and restoration of construction and labour camps to avoid or mitigate impacts on the environment. The area requirement for the construction camp shall depend upon the size of contract, number of labourers employed and the extent of machinery deployed. The following sections describe the siting, construction, maintenance, provision of facilities in the camps and finally rehabilitation of the construction and labour camps. These are described in three stages, pre-construction, construction and post-construction stage. The issues related to construction camps are similar in the case of road construction and hence have been taken together.

2. PRE-CONSTRUCTION STAGE

Identification of site for construction and labour camps is the first task. The Contractor shall identify the site for construction camp in consultation with the individual owners in case of private lands and the concerned department in case of Government lands. The suitable sites shall be selected and finalized in consultation with the Engineer -incharge. **Table 1** gives the lands that could be avoided for construction camps and conversely those that could be preferred.

Table 2-1: Selection Criterion for Construction Camps.

Avoid the following ...	Prefer the following ...
<ul style="list-style-type: none"> • Lands close to habitations. • Irrigated agricultural lands. • Lands belonging to small farmers. • Lands under village forests. Lands within 100m of community water bodies and water sources as rivers. • Lands within 100m of watercourses. • Low lying lands. • Lands supporting dense vegetation. • Grazing lands and lands with tenure rights. • Lands where there is no willingness of the landowner to permit its use. 	<ul style="list-style-type: none"> • Waste lands. • Waste Lands belonging to owners who look upon the temporary use as a source of income. • Community lands or government land not used for beneficial purposes. • Private non-irrigated lands where the owner is willing. • Lands with an existing access road.

The contractor will work out arrangements for setting up his facilities during the duration of construction with the land owner/concerned department. These arrangements shall be in the form of written agreement between the contractor and the land owner (private/government) that would specify:

- a) photograph of the proposed camp site in original condition;
- b) activities to be carried out in the site;
- c) environmental mitigation measures to be undertaken to prevent land, air, water and noise pollution;
- d) detailed layout plan for development of the construction and labour camp that shall indicate the various structures to be constructed in the camp including temporary, drainage and other facilities (**Figure 1** gives a layout plan for a construction camp); and
- e) Restoration plan of camp site to previous camp conditions.

The arrangements will be verified by the Engineer -incharge to enable redressal of grievances at a later stage of the project.

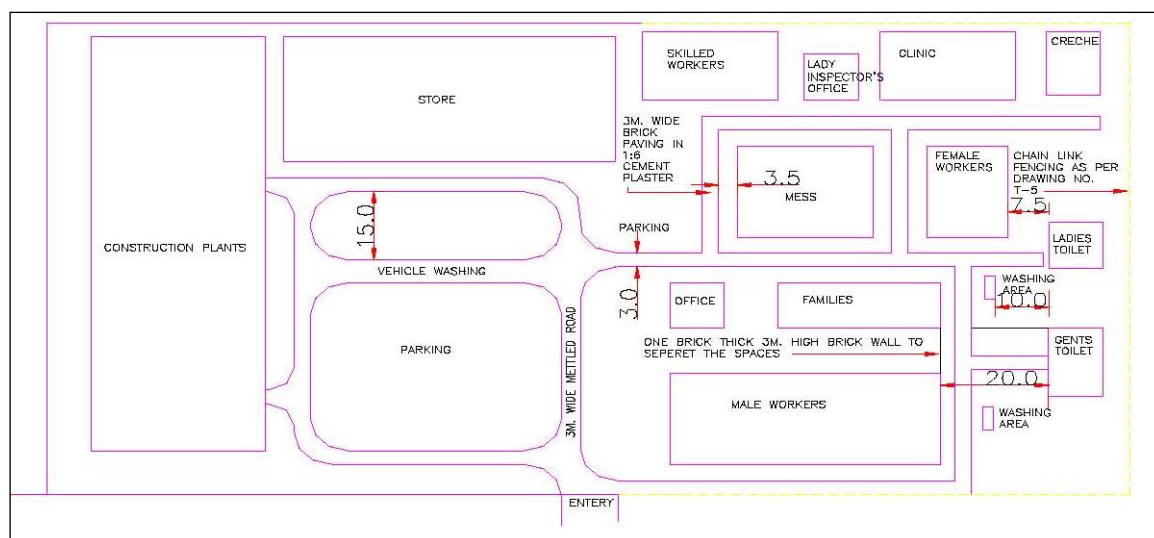

Figure 2-1: Layout Plan for Construction Camp

2.2 Setting up of labour camp

The contractor shall provide, free of cost in the camp site, temporary living accommodation to all the migrant workers employed by him for complete construction/maintenance work is in progress. A minimum area of 6 sq.mts per person shall be provided. The rooms of labour shall be well lighted and ventilated. The facilities to be provided for the labour are discussed below:

a) Drinking Water

Towards the provision and storage of drinking water at the construction camp, the contractor shall ensure the following provisions

- The contractor shall provide for a continuous and sufficient supply of potable water in the camps, in earthen pots or any other suitable containers.
- The contractor shall identify suitable community water sources for drinking. Only in the event of non-availability of other sources of potable water, the Contractor shall obtain water from an unprotected source only after the testing for its potability. Where water has to be drawn from an existing open well, the well shall be properly chlorinated before water is drawn from it for drinking. All such wells shall be entirely closed in and be provided with dust proof trap door.
- Every water supply or storage shall be at a distance of not less than 15m from any wastewater / sewage drain or other source of pollution. Water sources within 15m proximity of toilet, drain or any source of pollution will not be used as a source of drinking water in the project.
- A pump shall be fitted to covered well used as drinking water source, the trap door shall be kept locked and opened only for cleaning or inspection, which shall be done at least once a month.

b) Washing and Bathing Facilities

In every site, adequate and suitable facilities for washing clothes and utensils shall be provided and maintained for the use of contract labor employed therein. Separate and adequate bathing shall be provided for the use of male and female workers. Such facilities shall be conveniently accessible and shall be kept in clean and hygienic conditions.

c) Toilets Facilities

Sanitary arrangements, latrines and urinals shall be provided in every work place separately for male and female workers. The arrangements shall include:

- A latrine for every 15 females or part thereof (where female workers are employed).
- A latrine for every 10 males.
- Every latrine shall be under cover and so partitioned as to secure privacy, and shall have a proper door and fastenings.

- Where workers of both sexes are employed, there shall be displayed outside each block of latrine and urinal, a notice in the language understood by the majority of the workers “For Men Only” or “For Women Only” as the case may be.
- The latrines and urinals shall be adequately lighted and shall be maintained in a clean sanitary condition at all times and should have a proper drainage system;
- Water shall be provided in or near the latrines and urinals by storage in suitable containers.

d) Waste Disposal

- Disposal of sanitary wastes and excreta shall be into septic tanks.
- Kitchen waste water shall be disposed into soak pits/kitchen sump located preferably at least 15 meters from any water body. Sump capacity should be at least 1.3 times the maximum volume of wastewater discharged per day. The bottom of the pit should be filled with coarse gravel and the sides shored up with board, etc. to prevent erosion and collapse of the pit. New soak pits shall be made ready as soon as the earlier one is filled.
- Solid wastes generated in the kitchen shall be reused if recyclable or disposed off in land fill sites.

e) Medical and First Aid Facilities

Medical facilities shall be provided to the labour at the construction camp. Visits of doctor shall be arranged twice a month wherein routine checkups would be conducted for women and children. A separate room for medical checkups and keeping of first aid facilities should be built. The site medical room should display awareness posters on safety facilitation hygiene and HIV/AIDS awareness.

- First Aid Box will be provided at every construction campsite and under the charge of a responsible person who shall always be readily available during working hours. He shall be adequately trained in administering first aid-treatment. Formal arrangement shall be prescribed to carry injured person or person suddenly taken ill to the nearest hospital. The first aid box shall contain the following.
 - 6 small sterilized dressings
 - 3 medium size sterilized dressings
 - 3 large size sterilized dressings
 - 3 large sterilized burns dressings
 - 1 (30 ml) bottle containing 2 % alcoholic solution of iodine
 - 1 (30 ml) bottle containing salvolatile
 - 1 snakebite lancet
 - 1 (30 gms) bottle of potassium permanganate crystals
 - 1 pair scissors
 - Ointment for burns
 - A bottle of suitable surgical antiseptic solution

In case, the number of labour exceeds 50, the items in the first aid box shall be doubled.

f) Provision of Shelter during Rest

The work place shall provide four suitable sheds, two for meals and two for rest (separately for men and women). The height of the shelter shall not be less than 3.0m from the floor level to the lowest part of the roof. These shall be kept clean.

g) Crèches

In case 20 or more women workers are employed, there shall be a room of reasonable size for use of children under the age of six years. The room should have adequate light and realisation. A caretaker is to be appointed to look after the children. The use of the room shall be restricted to children, their mothers and the caretaker.

2.2 Storage of Construction Material in Construction Camps

For storage of Petrol/Oil/Lubricants, brick on edge flooring or sand flooring will be provided at the storage places of Petrol/Oil/Lubricants to avoid soil and water contamination due to spillage. These should be kept away from labour residential areas. The storage of cement shall be at Damp-proof flooring, as per IS codes. All materials shall be stored in a barricaded area. In case of electrical equipments, danger signs shall be

posted. The batch mix plant is to be located away from the residential area and not in the wind direction. Separate parking areas for vehicles and also workshop areas need to be provided.

2.2 Fire fighting arrangement

- The following precautions need to be taken:
- Demarcation of area susceptible to fires with cautionary signage;
- Portable fire extinguishers and/or sand baskets shall be provided at easily accessible locations in the event of fire;
- Contractor shall educate the workers on usage of these equipments.

2.2 Interactions with host communities

To ensure that there is no conflict of the migrant labor with the host communities, the contractor shall issue identity cards to labourers and residents of construction camps.

3. CONSTRUCTION STAGE

Construction camps shall be maintained free from litter and in hygienic condition. It should be kept free from spillage of oil, grease or bitumen. Any spillage should be cleaned immediately to avoid pollution of soil, water stored or adjacent water bodies. The following precautions need to be taken in construction camps.

- Measures to ensure that no leaching of oil and grease into water bodies or underground water takes place.
- Wastewater should not be disposed into water bodies.
- Regular collection of solid wastes should be undertaken and should be disposed off safely.
- All consumables as the first aid equipment, cleaning equipment for maintaining hygiene and sanitation should be recouped immediately.
- The debris/scrap generated during construction should be kept in a designated and barricaded area.

The Engineer - in-charge will monitor the cleanliness of construction campsites and ensure that the sites are properly maintained throughout the period of the contract.

4. POST CONSTRUCTION STAGE

At the completion of construction, all construction camp facilities shall be dismantled and removed from the site. The site shall be restored to a condition in no way inferior to the condition prior to commencement of the works. Various activities to be carried out for site rehabilitation include:

- Oil and fuel contaminated soil shall be removed and transported and buried in waste disposal areas.
- Soak pits, septic tanks shall be covered and effectively sealed off.
- Debris (rejected material) should be disposed off suitably (Refer **Guideline - 10** on “Waste Management and Debris Disposal”).
- Ramps created should be levelled.
- Underground water tank in a barren/non-agricultural land can be covered. However, in an agricultural land, the tank shall be removed.
- If the construction camp site is on an agricultural land, top soil can be spread so as to aid faster rejuvenation.
- Proper documentation of rehabilitation site is necessary. This shall include the following: –Photograph of rehabilitated site;
 - Land owner consent letter for satisfaction in measures taken for rehabilitation of site;
 - Undertaking from contractor; and
 - Certification from Engineer in-charge.

In cases, where the construction camps site is located on a private land holding, the contractor would still have to restore the campsite as per this guideline. Also, he would have to obtain a certificate for satisfaction from the landowner.

GUIDELINE-3: BORROW AREAS

1. INTRODUCTION

Embankment fill material is to be procured from borrow areas designated for the purpose. Borrow areas cause significant adverse environmental impacts if appropriate mitigation measures are not taken. The scope of this guideline includes measures that are required during project planning and design stage, pre-construction, construction stage and post construction stage. Borrow areas are related only to road construction activities.

2. PROJECT PLANNING AND DESIGN STAGE

Design measures for reduction in the quantity of the earthwork will have to be undertaken to reduce the quantity of material extracted and consequently decrease the borrow area requirement. Borrow area siting should be in compliance with IRC: 10-1961. The DPR shall contain (i) Guidelines for locating site of borrow areas and borrow material specifications.

3. PRE-CONSTRUCTION STAGE

The contractor shall identify the borrow area locations in consultation with the individual owners in case of private lands and the concerned department in case of government lands, after assessing suitability of material. The suitable sites shall be selected and finalized in consultation with the Engineer - incharge. Borrowing to be avoided on the following areas:

- Lands close to toe line.
- Irrigated agricultural lands (In case of necessity for borrowing from such lands, the topsoil shall be preserved in stockpiles. The subsequent Guidelines discuss in detail the conservation of topsoil.
- Grazing land.
- Lands within 0.8km of settlements.
- Environmentally sensitive areas such as Reserve Forests, Protected Forests, Sanctuary, wetlands. Also, a distance of 1000 m should be maintained from such areas.
- Designated protected areas / forests.
- Unstable side-hills.
- Water-bodies.
- Streams and seepage areas.
- Areas supporting rare plant/ animal species;
- Ensure unsuitable soft rock is not prominent within the proposed depth of excavation which will render rehabilitation difficult.

3.1 Arrangements for Borrow Area

The Contractor will work out arrangements for borrowing with the land owner/concerned department. The arrangements will include the redevelopment after completion of borrowing. The arrangements will be verified by the Engineer - incharge to enable redressal of grievances at a later stage of the project. The Engineer -Incharge shall approve the borrow area after inspection of the site to verify the reclamation plan and its suitability with the contractor and landowner. The contractor shall commence borrowing soil only after the approval by the Engineer - Incharge. The contractor shall submit to the Engineer-Incharge the following before beginning work on the borrow areas.

- Written No-objection certificate of the owner/cultivator;
- Estimate extent of earth requires;
- Extent of land required and duration of the agreement;
- Photograph of the site in original condition; and
- Site redevelopment plan after completion.

The depth of excavation should be decided based on natural ground level of the land and the surroundings, and rehabilitation plan. In case higher depth of excavation is agreed with backfilling by unsuitable

excavated soil (from roadway), then filling should be adequately compacted except topsoil, which is to be spread on the top most layer (for at least 20m thick). The guidelines for location, depth, size and shape of the borrow areas are available in the following:

- Clause 305.2.2.2 of MoRTH specification for roads and bridge works of IRC;
- Guidelines for environmental impact assessment of highway projects, Indian Roads Congress, 1989: (IRC: 104-1988);
- IRC: 10-1961-Recommended practice for borrow pits for road embankments constructed by manual operations, as revised in 1989;
- IRC SP: 58-2001 guideline for use of fly ash in road construction;
- EIA manual of MoEF, 2001;
- MoEF notification on utilisation of fly ash dated 27 August, 2005.

3.2 Documentation of Borrow Pit

The contractor must ensure that following data base must be documented for each identified borrow areas that provide the basis of the redevelopment plan.

- Chainage along with offset distance;
- Area (Sq.m);
- Photograph of the pit from all sides;
- Type of access/width/kutcha/puccaetc from the carriageway;
- Soil type;
- Slope/drainage characteristics;
- Water table of the area or identify from the nearest well, etc;
- Existing landuse, for example barren/agricultural/grazing land;
- Location/name/population of the nearest settlement from borrow area;
- Present usage of borrow area; and
- Community facility in the vicinity of borrow pit.

3.3 Redevelopment Plans for Borrow Pits

The following checklist provides guidelines in order to ensure that redevelopment of borrow areas must comply with MoRTH, clause 305.2.2.2 and EMP requirement. Borrow areas can be developed as:

- Ponds (various types) (eg: Drinking Water only; Washing and for other Domestic Chores; Only for Cattle; Mixed Uses etc.) (a large pond can be divided into two parts - each having a defined use)
- Farmland submission
- Water Recharging Zones
- Pastureland
- Fish Ponds (pisciculture)
- Waste disposal Sites (depending upon the location, distance from settlements, pollution risks, safety, associated environmental risks and hazards, regulations/ permissions of appropriate authority and other such factors)
- Plantation Zones
- Recreational Zones (depending upon location, size, potential of the site, willingness of the local bodies to develop it)
- Wildlife Refuge and Drinking Area (applicable only in case of sensitive environs with appropriate planning and understanding including regulation of depth for safety of animals etc.)

The rehabilitation measures for the borrow areas shall be dependent on the following factors:

- Land use objectives and agreed post-borrowing activities;
- Physical aspects (landform stability, erosion, re-establishment of drainage);
- Biological aspects (species richness, plant density,) for areas of native re vegetation;
- Water quality and soil standards; and

- Public safety issues.

Rehabilitation should be simple and maintenance free. Depending on the choice of the individual land owner/community, the contractor shall prepare redevelopment plans for the borrow areas. The options can be: (i) Restoring the productive use of the land (ii) Development of detention ponds in barren areas.

Option I: Suitable in locations with high rainfall and productive areas

Topsoil must be placed, seeded, and mulched within 30 days of final grading if it is within a current growing season or within 30 days of the start of the next growing season. Vegetative material used in reclamation must consist of grasses, legumes, herbaceous, or woody plants or a combination thereof, useful to the community for the fuel and fodder needs.

Plants must be planted during the first growing season following the reclamation phase.

Selection and use of vegetative cover must take into account soil and site characteristics such as drainage, pH, nutrient availability, and climate to ensure permanent growth. The vegetative cover is acceptable if within one growing season of seeding, the planting of trees and shrubs results in a permanent stand, or regeneration and succession rate, sufficient to assure a 75% survival rate.

Option II: In barren land, the borrow areas can be redeveloped into detention ponds.

These will be doubled up as water bodies and also for removal of sediment from runoff flowing through the ponds. Design of the detention basin depends upon the particle size, settling characteristics, residence time and land area. A minimum of 0.02 mm size particle with a settling velocity of 0.02 cm/sec (assuming specific gravity of solids 2.65) can be settled in the detention basin.

Following parameters are to be observed while setting up a detention pond:

- Pond should be located at the lowest point in the catchment area. Care should be taken that the horizontal velocity should be less than settling velocity to prevent suspension or erosion of deposited materials.
- Minimum Effective Flow Path: 5 times the effective width
- Minimum Free Board: 0.15 m
- Minimum Free Settling Depth: 0.5 m
- Minimum Sediments Storage Depth: 0.5 m
- Maximum interior slope: 2H : 1V
- Maximum exterior slope: 3H : 1V
- The inlet structure should be such that incoming flow should distribute across the width of the pond. A pre-treatment sump with a screen should provide to remove coarse sediments. Settled sediment should be removed after each storm event or when the sediment capacity has exceeded 33% of design sediment storage volume. Accumulated sediment must be disposed of in a manner, which will prevent its re-entry into the site drainage system, or into any watercourse.

4. CONSTRUCTION STAGE

No borrow area shall be operated without permission of the Engineer. The procurement of borrow material should be in conformity to the guidelines laid down in IRC: 10-1961. In addition, the contractor should adopt precautionary measures to minimise any adverse impacts on the environment. Checklists for monitoring borrow areas operation and management has been prepared (**Table 3-1**).

Table 3-1: Checklist for Monitoring Borrow Area Operation and Management

Attributes	Requirements
Access Road	Access road shall be used for hauling only after approved
Top soil preservation	To soil, if any, shall be stripped and stored at corners of the area before the start of excavation for material collection; Top soil should be reused / re-laid as per agreed plan; In case of riverside, borrow pit should be located not less than 15m from the toe of the bank, distance depending on the magnitude and duration of flood to be withstood. In no case shall be borrow pit be within 1.5m from the Toe line of the proposed embankment.
Depth of excavation	For agricultural land, the total depth of excavation should be limited to 150cm including top 30 cm for top

Attributes	Requirements
	soil preservation; For river side borrow area, the depth of excavation shall be regulated so that the inner edge of any borrow pit, should not be less than 15m from the toe of the bank and bottom of the pit should not cut the imaginary line of 1:4 projected from the edge of the final section of the embankment. To avoid any embankment slippage, the borrow areas will not be dug continuously, and the size and shape of borrow pits will be decided by the Engineer.
Damage to surrounding land	Movement of man and machinery should be regulated to avoid damage to surrounding land. To prevent damages to adjacent properties, the Contractor shall ensure that an undisturbed buffer zone exists between the distributed borrow areas and adjacent land. Buffer zone shall be 3 m wide or equal to the depth of excavation whichever is greater.
Drainage control	The Contractor shall maintain erosion and drainage control in the vicinity of all borrow pits and make sure that surface drains do not affect the adjacent land or future reclamation. This needs to be rechecked by the Engineer-Incharge.
Dust Suppression	Water should be sprayed on kutchha haul road twice a day or as may be required to avoid dust generation during transportation of material; Depending on moisture content, 0.5 to 1.5% water may be added to excavated soil before loading during dry weather to avoid fugitive dust emission.
Covering material for transport material	Material transport shall be provided with tarpaulin cover
Personal Protective Equipment	Workers should be provided with helmet, gumboots and air mask and their use should be strictly enforced.
Redevelopment	The area should be redeveloped within agreed timeframe on completion of material collection as per agreed rehabilitation plan.

5. POST CONSTRUCTION STAGE

All reclamation shall begin within one month of abandonment of borrow area, in accordance with the redevelopment plan. The site shall be inspected by the Engineer-Incharge after implementation of the reclamation plan. Certificate of Completion of Reclamation is to be obtained by the Contractor from the landowner that “the land is restored to his satisfaction”. The final payment shall be made after the verification by Engineer-Incharge.

6. CHECKLIST FOR INSPECTION OF REHABILITATION AREA

Inspection needs to be carried out by the Engineer - Incharge for overseeing the redevelopment of borrow areas as per the plan. The checklist for the inspection by the Engineer - Incharge is given below.

- Compliance of post-borrowing activities and land use with the restoration plan;
- Drainage measures taken for inflow and outflow in case borrow pit is developed as a detention pond;
- Levelling of the bottom of the borrow areas;
- In case the borrow area is on private property, the contractor shall procure written letter from landowner for satisfaction on rehabilitation. In case of no rehabilitation is desired by the landowner, the letter should include statement “no responsibility of R&BD on contractor in the event of accident.
- Condition of the reclaimed area in comparison with the pre-borrowing conditions.

GUIDELINE-4: TOPSOIL SALVAGE, STORAGE AND REPLACEMENT

1. INTRODUCTION

Loss of topsoil is a long term impact along roads due to (i) site clearance and widening for road formation (ii) development of borrow areas (iii) temporary construction activities such as construction camps, material storage locations, diversion routes etc. The environmental measures for both these activities during all stages of construction activity are discussed in the subsequent sections.

2. PROJECT PLANNING & DESIGN STAGE

At the project preparation stage, the following shall be estimated: (i) Extent of loss of top soil due to widening and siting of construction activities (ii) Estimates of borrow area requirements and (iii) Area requirement for topsoil conservation. The bid document shall include provisions that necessitate the removal and conservation of topsoil at all locations opened up for construction by the Contractor.

3. PRE-CONSTRUCTION STAGE

The arrangements for temporary usage of land, borrowing of earth and materials by the Contractor with the land owner/concerned department shall include the conservation / preservation of topsoil.

4. CONSTRUCTION STAGE

It shall be the responsibility of the Contractor to strip the topsoil at all locations opened up for construction. The stripped topsoil should be carefully stockpiled at suitable accessible locations approved by the Engineer - Incharge. At least 10% of the temporarily acquired area shall be earmarked for storing topsoil. In case of hilly and desert areas, topsoil with humus wherever encountered while opening up the site for construction shall be stripped and stockpiled. The stockpiles shall be located at:

- Areas away from Grade, Subsoil & Overburden materials;
- Areas away from pit activities and day-to-day operations;
- Areas that do not interfere with future pit expansion; and
- Areas away from drainage paths and uphill of sediment barriers.

The stockpiles for storing the topsoil shall be designed such that the slope should not be less than 1:2 (Vertical to horizontal), and the height of the pile is restricted to 2m. A minimum distance of 1m is required between stockpiles of different materials.

In cases where the topsoil has to be preserved for more than a month, the stockpile is to be stabilised within 7 days of forming. The stabilisation shall be carried out through temporary seeding. It consists of planting rapid-growing annual grasses or small grains, to provide initial, temporary cover for erosion control.

After spreading the topsoil on disturbed areas, it must be ensured that topsoil is seeded, and mulched within 30 days of final grading. During construction, if erosion occurs from stockpiles due to their location in small drainage paths, the sediment-laden runoff should be prevented from entering nearby watercourses. The Contractor shall preserve the stockpile material for later use on slopes or shoulders as instructed by the Engineer.

Vegetative material for stockpile stabilisation...

Must consist of grasses, legumes, herbaceous, or woody plants or a mixture thereof • Selection & use of vegetative cover to take into account soil and site characteristics such as drainage, pH, nutrient availability, and climate to ensure permanent growth

Vegetative material for stockpile stabilisation...

Stockpiles will not be surcharged or otherwise loaded and multiple handling will be kept to a minimum to ensure that no compaction will occur.

Divert runoff around stockpiles unavoidably located in drainage paths using a perimeter bank uphill.

The stockpiles shall be covered with gunny bags or tarpaulin immediately in case they are not stored for periods longer than 1 month

5. POST CONSTRUCTION STAGE

The topsoil shall be re-laid on the area after taking the borrow earth to maintain fertility of the agricultural

field, finishing it to the required levels and satisfaction of the farmer. The area to be covered with vegetation shall be prepared to the required levels and slope as detailed in the DPR. The stockpile material shall be spread evenly to a depth of 5-15cm to the designed slopes and watering the same as required. The growth of the vegetation shall be monitored at frequent intervals. All temporary arrangements made for stockpile preservation and erosion control are to be removed after reusing the stockpile material. The top soil can also be used for the following purposes:

- a. Covering the borrow areas;
- b. Embankment and turfing;
- c. Median; and
- d. Rehabilitation of construction and labour camp.

GUIDELINE-5: QUARRY MANAGEMENT**1. INTRODUCTION**

This guideline pertains to the measures to be taken to address environmental concerns in quarry areas. The general practice adopted is to procure materials from existing quarries operating with the requisite permits. The measures to be taken for operation and management for quarries during all stages of construction have been discussed in this Guideline.

2. PROJECT PLANNING AND DESIGN STAGE

The PIU shall provide in the DPR / bid document, a list of licensed quarries operating within the district and adjoining districts. In addition, the DPR shall contain the following: (i) Quantity of materials available in quarries (ii) Lead from the various existing quarries and (iii) Adequacy of materials for the project in these quarries. **Table 5-1** and **5-2** give the format for preparing a list of quarries.

Table 5-1 Details of Sand Quarry

Sample No.	Source of Sand	Name of quarry area	Site Identification/ Location			Approximate Quantity (cum)	Approximate basic cost of the material (Rs.)	Remarks
			Nearest Chainage (Km.)	Left/Right	Offset from nearest chainage (km)			

Table 5-2 Details of Quarry Area for Aggregates

Sample No.	Chainages (Km.)	Left/ Right	Name of Quarry Area	Name of Crusher	Lead from nearest chainage (Km.)	Basic cost of the material (Rs.)	Available land/terrain	Surrounding land Terrain	Remarks
------------	-----------------	-------------	---------------------	-----------------	----------------------------------	----------------------------------	------------------------	--------------------------	---------

Only in the event of non-availability of existing quarries, the Contractor shall open a new quarry in accordance with Mines and Minerals (Development & Regulation) Act, 1957. The bid document shall include the exhaust quarry reclaim plan per needs of the landowner / community.

3. PRE-CONSTRUCTION STAGE

The Contractor shall select an existing licensed quarry identified in DPR for procuring materials. The Contractor shall establish a new quarry with the prior consent of the Engineer - Incharge only in cases when: (i) Lead from existing quarries is uneconomical and (ii) Alternative material sources are not available. The Contractor shall prepare a Redevelopment Plan for the quarry site and get it approved by the Engineer - Incharge.

The construction schedule and operations plans to be submitted to the Engineer - Incharge prior to commencement of work shall contain a detailed work plan for procuring materials that includes procurement, transportation and storage of quarry materials.

4. CONSTRUCTION STAGE**4.1 Development of Quarry Area**

To minimize the adverse impact during excavation of material following measures are need to be undertaken:

- Adequate drainage system shall be provided to prevent the flooding of the excavated area
- At the stockpiling locations, the Contractor shall construct sediment barriers to prevent the erosion of excavated material due to runoff.
- Construction of offices, laboratory, workshop and rest places shall be done in the up-wind of the plant to minimize the adverse impact due to dust and noise.

- The access road to the plant shall be constructed taking into consideration location of units and also slope of the ground to regulate the vehicle movement within the plant.
- In case of storage of blasting material, all precautions shall be taken as per The Explosive Rules, 1983.

4.2 Setting up of Crushers and other equipments

The following measures shall be undertaken for setting up of crushers and other equipments.

- The contractor shall obtain “No Objection Certificate (NoC)” from the Gujarat State Pollution Control Board.
- All vehicles must possess Pollution Under Control (PUC) Certificate and shall be renewed accordingly
- All machinery, equipments, and vehicles shall comply with existing CPCB noise and emission norms.
- The Engineer - Incharge must ensure that contractor shall submit the copy of NoC and PUC Certificate before the start of work.

4.3 Quarry operations

The following precautions shall be undertaken during quarry operations. vii) Overburden shall be removed and disposed as per **Guideline 8** “Waste Management and Debris Disposal”.

- During excavation slopes shall be flatter than 20 degrees Guideline 8 on to prevent their sliding
- In case of blasting, the procedure and safety measures shall be taken as per The Explosive Rules, 1983
- The Contractor shall ensure that all workers related safety measures shall be done as per measures for, “Labour & Workers Health & Safety” (**Guideline 12**).
- The Contractor shall ensure maintenance of crushers regularly as per manufacturer’s recommendation.
- Stockpiling of the excavated material shall be done as per stockpiling of topsoil explained in **Guideline 4**, “Topsoil Salvage, Storage & Replacement.”
- During transportation of the material, measures shall be taken as per **Guideline 11** “Construction Plants and Equipment Management” to minimize the generation of dust and to prevent accidents
- The Engineer-Incharge and the concerned authority shall review the quarry site for the management measures during quarry operation, including the compliance to pollution norms.

5. POST CONSTRUCTION STAGE

A quarry redevelopment plan shall be prepared by the Contractor. All haul roads constructed for transporting the material from the quarries to construction site shall be restored to their original state.

The Engineer - Incharge and the concerned authority shall be entrusted the responsibility of reviewing the quarry site for the progress of implementation of Redevelopment Plan.

The plan shall include:

- Photograph of the quarry site prior to commencement
- The quarry boundaries as well as location of the materials deposits, working equipments, stockpiling, access roads and final shape of the pit.
- Drainage and erosion control measures at site
- Safety measures during quarry operation
- Design for redevelopment of exhaust site.

Two options for redevelopment of quarry areas are given below:

Option A: *Vegetating the quarry to merge with surrounding landscape.* This is done by conserving and reapplying the topsoil for the vegetative growth.

Option B: *Developing exhausted quarries as water bodies.* The pit shall be reshaped and developed into pond, for harvesting rainwater. This option shall only be considered where the location of quarry is at the lowest point, i.e. surrounding areas/ natural drainage slopes towards it.

GUIDELINE-6: WATER FOR CONSTRUCTION

1. INTRODUCTION

The scope of this guideline includes the procurement of water required for construction of roads. Except bituminous works, water is required during all stages of road construction such as Embankment Sub-Grade; Granular sub-base (GSB) and Water Bound Macadam (WBM). Management of water in various stages of construction is given in the following sections.

2. PROJECT PLANNING & DESIGN STAGE

- The Detailed Project Report for both road constructions shall contain the following information:
- Estimate of water requirement during different seasons based on construction schedule of various stages of construction.
- Identification of potential sources of water for construction,
- Arrangements to be worked out by the contractor with individual owners, when water is obtained from private sources, and
- Whether scarcity of water would have any impact on schedule of construction.

In water-scarce regions, provide the following additional information in Project Reports...

- Exploring possibilities for use of existing perennial sources, through interactions with water user groups as the villagers, relevant Government Departments, keeping in view that the water extraction does not infringe upon the usufruct rights of the existing water users.
- Identification of potable water source for domestic use of workers and for use in cement - based construction such as cement concrete roads, culverts and other cross drainage works.
- Identification of alternate water sources, water-harvesting techniques will be explored to avoid water extraction from the existing community sources.

In water scarce regions, if water-harvesting structures are to be constructed, suitable locations and mechanism for siting these structures will be identified. These are envisaged to be permanent water tanks for collection of stream water. Detailed drawings of water harvesting structures based on site conditions will need to be worked out and presented in the DPR. No extra payment shall be generally made for these works and the Contractor has to include the cost of these items in his offer while quoting his tendered rate.

Scheduling Construction in Water Scarce Areas: As part of the project preparation, the Engineer - Incharge shall conduct an assessment of water requirement and availability in water scarce regions. As far as possible, schedule for construction in these water scarce areas shall be prepared such that earthwork for embankment is carried out just before monsoon, so that water requirement for subsequent construction works such as granular sub-base and water bound macadam are met in monsoon and post monsoon season. Carrying out these activities even during the monsoon is possible as the rainfall may not be high enough to disrupt construction.

3. PRE-CONSTRUCTION STAGE

Prior to commencement of extraction of water for construction, the contractor shall work out arrangements as specified in the DPR.

In water-scarce regions, provide the following additional information in Project Reports...

- Exploring possibilities for use of existing perennial sources, through interactions with water user groups as the villagers, relevant Government Departments, keeping in view that the water extraction does not infringe upon the usufruct rights of the existing water users.
- Identification of potable water source for domestic use of workers and for use in cement - based construction such as cement concrete roads, culverts and other cross drainage works.
- Identification of alternate water sources, water-harvesting techniques will be explored to avoid water extraction from the existing community sources.
from any septic tank/soak pit or other source of pollution.
- **In case of water harvesting structures** (if required), the Contractor shall in consultation with the residents, identify suitable locations for siting the structure and construct the same.
- **In case of perennial sources**, the Contractor shall adhere to all administrative procedures pertaining to procurement of water from such sources.

CONSTRUCTION STAGE

During construction, the Contractor shall be responsible to monitor the following:

- The arrangements worked out with the Panchayat/individual land owners for water extraction is adhered to;
- Extraction of water is restricted to construction requirement and domestic use of construction workers;
- Water requirement for curing of concrete shall be minimized by pooling of water over the concrete or by covering with wet gunny bags; and
- The potable water used for drinking purposes of construction workers shall be as per the Indian Standard for Drinking Water IS: 10500, 1991.

GUIDELINE-7: SLOPE STABILITY AND EROSION CONTROL

1. INTRODUCTION

Stability of slopes is a major concern in locations of high embankment. In cases of high embankment, water retention at the embankment base initially causes toe failure and subsequently failure of the whole embankment. Soil erosion is consequent to high runoff on hill slopes. Embankments made up of silty and sandy soils get eroded, in the absence of vegetative cover, when the slopes are steep say more than 20 Degree.

The scope of this guideline includes measures to minimize the adverse environmental impacts due to slope instability and soil erosion. The adverse environmental impact can be: (i) Damage to adjacent land, (ii) Silting of ponds and lakes disturbing the aquatic habitat (iii) Erosion of rich and top fertile top layer of soil (iv) Contamination of surface water bodies and (v) Reduction in road formation width due to erosion of shoulders/berms.

2. PROJECT PLANNING AND DESIGN STAGE

During the detailed project preparation phase, the following investigations shall be carried out prior to finalisation of alignment.

- Topographical;
- Hydrological;
- Geo-technical; and
- Geological Investigation (in case of roads in hill areas and areas of high seismic activity)

In addition to the slope stability analysis the alignment should be such that (i) steep as well as heavy cuts are avoided, (ii) Flora and fauna of the area are not disturbed and (iii) Natural drainage pattern is not obstructed.

For high embankments, geo-technical investigations (determination of C , ϕ , density etc.) of the available material need to be done to check its suitability as fill material.

In case of the CD structures, measures for preventing siltation and scouring shall be undertaken as per Guideline on, "Drainage".

Following guidelines shall be followed in desert areas while using cohesion-less soils for embankment construction.

- The alignment should follow the natural ground level to the extent possible and the embankment shall be restricted to minimum to achieve ruling grades.
- Slope of the embankment should be 3 (H): 1(V) or flatter.
- The corners of the embankment should be rounded for better aerodynamic performance.

3. PRE-CONSTRUCTION STAGE

Interceptor ditches are constructed along hilly slopes or areas with high rainfall to protect the road bench and hillside slope from erosion due to heavy rainfall and runoff. Interceptor ditches are very effective in the areas of high intensity rainfall and where the slopes are exposed. These are the structures designed to intercept and carry surface run-off away from erodible areas and slopes, thus reducing the potential surface erosion. The Engineer - Incharge must ensure that the layout and siting of ditches is as per specifications.

4. CONSTRUCTION STAGE

When alternative material such as fly ash is used for embankment formation, it needs to be ensured that sufficient filter bed is provided along with the top cap. All tests as per IS: 2720 (Parts: 4, 5, 8 & 40) and IRC: SP: 20-2002 are to be conducted on the embankment to keep a check on the compaction achieved. Slope stabilisation techniques and erosion control measures such as vetiver grass, stone pitching, use of geotextile and turfing.

Box-1: Detailed specifications for Vegetative cover

Description:

The vegetative cover should be planted in the region where the soil has the capacity to support the plantation and at locations where meteorological conditions favours vegetative growth.

Site Preparation:

- To prevent the seeds from being washed away subsequent to sowing, the area should be protected with surface roughening and diversions.
- Soil samples should be taken from the site and analysed for fertiliser and lime requirements.

Seed Application:

- The seed should be sown uniformly as soon as preparation of the seedbed has been completed.
- No seed should be sown during windy weather. The best time for seeding would be during monsoon.

Maintenance:

During first six weeks, the planting should be inspected by the PIC, to check if the growth is uniform and dense. Appropriate moisture levels shall be maintained. There may be requirement of watering the plantings regularly during the dry seasons.

5. POST CONSTRUCTION STAGE

All the exposed slopes shall preferably be covered with vegetation using grasses, brushes etc. Locally available species possessing the properties of (i) good growth (ii) dense ground cover and (iii) deep root shall be used for stabilization.

In case of steep and barren slopes, in order to retain the seedling to the ground asphalt mulch treatment shall be given. Seedling are covered with asphalt emulsion and spread into a thin layer. The asphalt film gradually disintegrates and a carpet of green vegetation and deep-rooted species of grass and clovers, takes its place. Anchoring shall be carried out as per IRC: SP: 48-1998.

Regular inspection of check dams and repositioning/replacement of dislodged or stolen stones need to be carried out.

Repair and maintenance of eroded side drain inverts is to be done in order to arrest retrogradation of levels in side drains. Slopes of high embankment can give a fertile base for growth of vegetative cover / sodding.

In arid areas, in order to avoid the deposition of sand over or near the road surface, shrubs are to be planted at an appropriate distance from the formation. The shrubs should not be abutting the road and the distance for carrying out plantation shall be determined based on prevalent wind speeds as well as quantity of sand being carried amongst various other factors. There should be a clear gap between the roadway and shrubs to allow the wind to pick up its velocity and carry along with it any sand that is deposited.

GUIDELINE-8: WASTE MANAGEMENT AND DEBRIS DISPOSAL

1. INTRODUCTION

This guidance describes procedures for handling, reuse and disposal of waste materials during road construction. The Guideline describes waste management measures in all stages of construction. Also, the Guideline discusses the measures to be taken for debris disposal.

2. PROJECT PLANNING AND DESIGN STAGE

As part of DPR preparation, the Engineer - Incharge shall carry out the following measures

- Finalize road design and alignment to minimize waste generation through balancing of cut and fill operations and minimizing excess cuts requiring disposal.
- Identify the type of wastes as well as sources of waste during construction and suggest options for possible reuse
- Provide guidelines to the contractor for locating waste disposal sites for non-toxic wastes
- Identify existing landfill sites if available for disposal of toxic materials.
- In case no existing landfill sites are available, identification of landfill site as well as identification of the clearance requirements.
- Identify sites of disposal of debris.

3. PRE-CONSTRUCTION STAGE

The contractor shall identify the activities during construction, that have the potential to generate waste and work out measures for reducing, reusing and proper disposing of the generated waste in the construction schedule to be submitted to the Engineer - Incharge. A sequential listing of the activities during road construction and the nature of wastes together with the possible options for reuse are specified in **Table 8-1**. For the disposal of excess cut and unsuitable (non-toxic) materials, the contractor shall identify the location for disposal in consultation with the community / concerned department. Any toxic materials shall be disposed in existing landfill sites that comply with legislative requirements. Prior to disposal of wastes onto private/community land, it shall be the responsibility of the Contractor to obtain a No-objection Certificate (NOC) from the land owner/community. The NOC shall be submitted to the Engineer - Incharge prior to commencement of disposal.

The Contractor shall educate his workforce on issues related to disposal of waste, the location of disposal site as well as the specific requirement for the management of these sites.

Practices to avoid – waste disposal ...
<ul style="list-style-type: none"> •Tipping of waste into stream channels, water bodies, forests and vegetated slopes •Non-cleaning of wastes after day's work •Leaching of wastes •Littering in construction camps / sites •Storing wastes on private land

4. CONSTRUCTION STAGE

The contractor shall either reuse or dispose the waste generated during construction for roads depending upon the nature of waste, as specified in **Table 1**. The reuse of waste shall be carried out by the contractor only after carrying out the specific tests and ascertaining the quality of the waste materials used, and getting the same approved by the Engineer - Incharge. Wastes that were not reused shall be disposed off safely by the contractor. The contractor shall adopt the following precautions while disposing wastes:

- Bituminous wastes shall be disposed off in 60mm thick clay lined pits and covered with 30cm good earth at top, so as to facilitate growth of vegetation in long run.
- In case of filling of low-lying areas with wastes, it needs to be ensured that the level matches with the surrounding areas. In this case care should be taken that these low lying areas are not used for rainwater storage
- In case oil and grease are trapped for reuse in a lined pit, care shall be taken to ensure that the pit should be located at the lowest end of the site and away from the residential areas.

The waste management practices adopted by the Contractor, including the management of wastes at construction camps etc shall be reviewed by the Engineer - Incharge and the Pollution Control Board (PCB) during the progress of construction.

5. POST CONSTRUCTION STAGE

On decommissioning of construction sites, the Contractor shall hand over the site free of all debris/wastes to the satisfaction of Engineer - Incharge. In case of any temporary disposal of wastes on private land, certificate of Completion of Reclamation is to be obtained by the Contractor from the landowner that “the land is restored to his satisfaction”. The same is to be submitted to the Engineer - Incharge before final payment is claimed.

Table 8-1: Type of wastes and scope for reuse- road construction

S. No	Activity	Type of waste	Scope for possible reuse	Disposal of waste
I CONSTRUCTION WASTES				
1.	Site Clearance and grubbing	Vegetative cover and top soil Unsuitable material in embankment foundation	Vegetating embankment slopes Embankment Fill	Low lying areas Land fill sites
2.	Earthworks			
a)	Overburden of borrow areas	Vegetative cover and soil	Vegetating embankment slopes	
b)	Overburden of quarries	Vegetative cover and soil Granular material	Vegetating embankment slopes Embankment Fill, Pitching	
c)	Accidental spillages during handling	Dust		
d)	Embankment construction	Soil and Granular Material	Embankment Fill	
e)	Construction of earthen drains	Soil	Embankment Fill	
3.	Concrete structures Dust			
a)	Storage of material	Dust, Cement, Sand Metal Scrap	Constructing temporary structure, embankment fill	Scrap Yard
b)	Handling of materials	Dust		
c)	Residual wastes	Organic matter Cement, sand Metal scrap	Manure, Revegetation Constructing temporary structure, embankment fill Diversion sign, Guard Rail	
4	Reconstruction works			
a)	Dismantling of existing pavement	Bitumen Mix, granular material Concrete Guard rail sign post, guard stone	sub-base Road Sub-base, reuse in concrete, fill material and as rip rap on roads Reuse for same	
b)	Dismantling of cross drainage structures	Granular material & bricks Metal scrap Pipes	Constructing temporary structure, embankment fill Diversion sign, Guard Rail Culvert Culvert	
5	Decommissioning of sites			

S. No	Activity	Type of waste	Scope for possible reuse	Disposal of waste
a)	Dismantling of temporary structures	Granular material and bricks	Constructing temporary structure, embankment fill	
6	Maintenance operation			
a)	Desilting of side drains	Organic matter and soil	Revegetation	
II OIL AND FLUIDS				
1	Construction machinery – maintenance and refueling	Oil and Grease	Incineration, Cooking, Illumination	
2	Bituminous works			
a)	Storage	Bitumen	Low Grade Bitumen Mix	
b)	Mixing and handling	Bitumen Bitumen Mix	Low Grade Bitumen Mix Sub-base, Paving access & cross roads	
c)	Rejected bituminous mix	Bitumen Mix	Sub-base, Paving access & cross roads	
III DOMESTIC WASTES				
1	Construction camps	Organic waste, Plastic and metal scrap Domestic effluent	Manure Irrigation	Scrap Yard

6. Disposal of Debris

For the purpose of disposal of debris, dumping sites need to be selected. The criteria for selection of dumping sites include:

- No residential areas are located downwind side of these locations;
- Dumping sites are located at least 1000 m away from sensitive locations;
- Dumping sites do not contaminate any water sources, rivers etc; and
- Dumping sites have adequate capacity equal to the amount of debris generated;
- Public perception about the location of debris disposal site has to be obtained before finalizing the location;
- Permission from the Village Panchayat is to be obtained for the dumping site selected;
- Productive lands are avoided; and
- Available waste lands shall be given preference

GUIDELINE-9: WATER BODIES

1. INTRODUCTION

Water bodies may be impacted when the road construction is adjacent to it or the runoff to the water body is affected by change of drainage pattern due to construction of embankment. The following activities are likely to have an adverse impact on the ecology of the area:

- Earth moving;
- Removal of vegetation;
- Vehicle/Machine operation and maintenance;
- Handling and laying of asphalt; and
- Waste disposal from construction camps.

2. PROJECT PLANNING AND DESIGN STAGE

All efforts are to be taken to avoid the alignments passing adjacent or close to water bodies. Where possible, it should be realigned away from the water body without cutting its embankment, decreasing the storage area or impairing the catchment area. Adequate drainage arrangements as per IRC guidelines have to be provided. Stream bank characteristics and hydrology of the area are to be studied before finalizing the alignment, the profile and cross-drainage structures.

Complete filling of water body with soil is not contemplated in the project. The DPR and its cost estimates have to accommodate costs of rehabilitation (to be estimated as lump sum at DPR stage) of water bodies impacted by the project. Water body rehabilitation shall be as per the Rehabilitation Plan prepared by the Contractor which should have approval of the Engineer - Incharge. Details of the tasks to be performed as per the sequence of activities during the project planning and design are as follows:

- Consultations with the people regarding alternate routes that were devised to avoid the pond. If alternate routes are not available, consent of the villagers is to be sought for affecting the pond and also the measures that would be taken to mitigate the impacts.
- Final design is to be prepared indicating the pond location in the alignment drawings.
- If impacting the pond, the extent of impact is to be clearly indicated on a separate drawing showing blown up portion of the pond. The drawing should aid the contractor in setting up exact lines for cutting the pond.
- All necessary measures for mitigation of impacts and precautionary measures while working close to the water body are to be incorporated into the DPR and cost estimates. The measures to be incorporated shall be as per this guideline.

PRE-CONSTRUCTION STAGE

The Contractor after an assessment of the likely impacts on the water body and review of the provisions of this guideline shall prepare a detailed work plan at the pre-construction stage. The Contractor shall prepare a Rehabilitation Plan for rectifying the likely impact to be caused and approval of Engineer - Incharge shall be sought prior to commencement of work. The Rehabilitation Plan should include:

- Locations of erosion protection works and silt fencing to prevent sediment laden runoff entering the water body;
- Location of side drains (temporary or otherwise) to collect runoff from the embankment before entering the water body in accordance with IRC guidelines;
- Work program in relation to the anticipated season of flooding/overflowing of the water body;
- Obstructions likely to cause temporary flooding and information to seek clearance to remove the

Impacts on water bodies impairs ...

- Change in Catchment area of the water body
- Drainage system
- Flood level and water logging
- Flora and fauna dependant on the water body
- Ground water recharging
- Animal husbandry as water bodies are used by animals
- Water quality &
- Runoff (increase/decrease)

obstruction; and

- Drawings in Rehabilitation Plan should indicate the landscape details along with species to be planted in the surrounding environs of the water body.

The rehabilitation of water body should be with the objective of restoring it to its original state or to a better state with necessary enhancement of its environs. Rehabilitation Plan shall include:

- Reconstruction and stabilization of embankment in case it is impacted;
- If storage area is lost, then the water body is to be deepened to regain an equivalent volume;
- Further enhancement of the water body as a focal point with place for seating and provision of shade; and
- Costs of rehabilitation

Concurrence of the community has to be sought on the Rehabilitation Plan prepared by the Contractor. Concerns of the community have to be incorporated into the plan before submitting it for approval of the Engineer - Incharge.

The Engineer - Incharge shall scrutinize the Rehabilitation Plan, verify the implementation on site and finally approve the plan. The Rehabilitation Plan should be implemented by the Contractor immediately after completion of construction at the stretch near the water body.

When there is interruption to regular activities of villagers near water body due to construction or rehabilitation work, following are the Contractor's responsibilities:

- Restriction on use of water, if any, should be intimated to the community in advance;
- Alternate access to the water body is to be provided in case there is interruption to use of exiting access. The access provided should be convenient for use of all the existing users whether community or cattle; and
- If the water body affected is a drinking water source for a habitation, alternate sources of water are to be provided to the users during the period for which its use is affected.

3. CONSTRUCTION STAGE

It should be ensured by the contractor that the runoff entering the water body is free from sediments

Silt fencing and/or brush barrier shall be installed in the drainage channels for collecting the sediments before letting them into the water body. Silt/sediment should be collected and stockpiled for possible reuse as surfacing of slopes where they have to be revegetated. Cutting of embankment reduces the water retention capacity and also weakens it, hence:

- The contractor should ensure that the decrease in water retention should not lead to flooding of the construction site and surroundings causing submergence and interruption to construction activities.
- Any perceived risks of embankment failure and consequent loss/damage to the property shall be assessed and the contractor should undertake necessary precautions as provision of toe protection, erosion protection, sealing of cracks in embankments. Failure to do so and consequences arising out of embankment failure shall be the responsibility of the contractor. The Engineer - Incharge shall monitor regularly whether safe construction practices near water bodies are being followed.

Alternate drain inlets and outlets shall be provided in the event of closure of existing drainage channels of the water body. Movement of machinery and workforce shall be restricted around the water body, and no waste from construction camps or sites shall be disposed into it.

Working near Water Bodies – Precautions

- Avoid locating roads on pond embankment
- Collect road runoff before entering the water bodies
- Runoff to be filtered of sediments before letting into water bodies
- Avoid debris disposal into water bodies
- Avoid disposal of oil/grease/other contaminants into water bodies

4. POST CONSTRUCTION STAGE

With the completion of construction, the Engineer - Incharge has to ensure implementation of rehabilitation/restoration plan for the water body, as indicated by the Contractor in the bid submission. The precincts of the water body have to be left clean and tidy with the completion of construction. Drainage channels of adequate capacity shall be provided for the water body impacted.

GUIDELINE-10: DRAINAGE

1. INTRODUCTION

Inadequate and faulty drainage arrangements during road construction result in obstruction to natural drainage pattern. The problem is further aggravated in the low-lying areas and flood plains receiving high intensity rainfall, which can lead to the instability of embankment, damage to pavement, sinking of foundation, soil erosion, safety hazards and disruption in traffic. Provision of cross-drainage and longitudinal drainage increases the life of the road and consequently reduces water logging and related environmental impacts. The functioning of the drainage system is therefore a vital condition for a satisfactory road.

However, construction or upgradation of CD structures and longitudinal drains is likely to increase sediments, scour the banks, change water level and flow, and also affect the ecology of the surrounding area. The guideline shall address the environmental concerns related to drainage aspects during different stages of the project execution.

2. PROJECT PLANNING AND DESIGN

Drainage shall be broadly divided as (i) Cross-Drainage and (ii) Longitudinal Drainage both surface & subsurface drainage. The alignment shall be routed such that minimum drainage crossings are encountered. Also the geometric design criteria as per IRC 73, guidelines for effective surface drainage should be ensured.

All drains crossing the alignment shall be identified on site and marked on map while undertaking transect walk. Basic information on the width of channel, frequency of traffic holdup and flow would provide inputs into screening of alternate alignments as well as fixing the alignment. Consultations with the community shall provide information on the HFL in the area.

In areas of high and medium intensity rainfall (>400 mm/year), flood prone areas and hilly areas, detailed hydrological studies will need to be conducted. The studies shall be conducted as per IRC: SP-13: 1973 “Guidelines for the Design of Small Bridges & Culverts” and IRC: SP-33:1989 “Guidelines on Supplemental Measures for Design, Detailing & Durability of Important Bridge Structures”.

Design of cross-drainage structures shall be based on the inputs from the hydrological studies as per clause 12.2.3 and in other areas, the C-D structure design shall be as per IRC: SP-13. Design of C-D structure shall be such that:

- Normal alignment of the road is followed even if it results in a skew construction of culverts and stream bank protections are incorporated.
- Afflux generated is limited to 30 cm in plains with flat land slopes.
- It is fish friendly – fish passage is not interrupted either in upstream or downstream direction.
- Adequate scour protection measures for stream bank, roadway fill as head walls, wing walls and aprons are included.
- Reinforced road bed (of concrete or rock) for protection against overflow in case of low water crossing (floods/causeways) is included.
- The design of C-D structure (minor and major bridge) should have stairs leading to the bed of the drainage channel, for regular inspection of the sub-structure.
- Schedule of construction of C-D structures should be confined to dry months to avoid contamination of streams.

Longitudinal drains are to be designed to drain runoff from highest anticipated rainfall as per rainfall data for the past 20 years or 50 years as per hydrological analysis in high rainfall areas (annual rainfall > 1000 mm) and hill areas. For design of longitudinal drains in other areas, the design shall be as per IRC: SP-20:2002.

Outfall of the roadside drains shall be into the nearby stream or culvert. The outfall should be at such

a level that there would be no backflow into the roadside drain. Wherein pond/low lying areas exist in the vicinity, the flow may be diverted into them after removal of sediment for possible ground water recharge.

In case of high embankment (>1.0m) or bridge approaches, lined channels shall be provided to drain the surface runoff, prevent erosion from the slopes and avoid damage to shoulders and berms. Detailed specifications shall be as per IRC: SP-20:2002. The type of drains that can be constructed include bricklined, pucca with RCC, covered drain with RCC slabs and piped drain.

3. PRE-CONSTRUCTION STAGE

Following measures are to be undertaken by the contractor prior to the commencement of CD/Bridge construction:

- The downstream as well as upstream user shall be informed one month in advance
- The contractor shall schedule the activities based on the nature of flow in the stream.
- The contractor should inform the concerned departments about the scheduling of work. This shall form part of the overall scheduling of the civil works to be approved by Engineer - Incharge.
- Erosion and sediment control devices are to be installed prior to the start of the civil works.
- Interceptor drains to be dug prior to slope cutting to avoid high runoff from slopes entering construction sites in case of hill roads
- Runoff from temporary drains and interceptor drains to be directed into natural drains in hill roads
- In case of up-gradation of the existing CD Structures, temporary route / traffic control shall be made for the safe passage of the traffic, depending upon the nature of the stream
- All the safety/warning signs are to be installed by the contractor before start of construction

In case of utilization of water from the stream, for the construction of the CD structures, the contractor has to take the consent from the concerned department (refer Guideline on “Water for Construction”)

4. CONSTRUCTION PHASE

Drainage structures at construction site shall be provided at the earliest to ensure proper compaction at the bridge approach and at the junction of bridge span and bridge approach. Velocity of runoff to be controlled to avoid formation of rills/gullies as per guideline, “Slope stability & erosion control”

While working on drainage channels, sediment control measures shall be provided. Silt fencing (as per the detailed specifications of guideline, “Slope Stability & Erosion Control”) shall be provided across the stream that carries sediment.

The sediments collected behind the bunds shall be removed and after drying, can either be reused or disposed off as per guideline, “Waste Management and Debris Disposal”. Safety devices and flood warning signs to be erected while working over streams and canals.

5. POST CONSTRUCTION

Inspection and cleaning of drain shall be done regularly to remove any debris or vegetative growth that may interrupt the flow. HFL should be marked as per hydrological data on all drainage structure. Temporary structure constructed during construction shall be removed before handing over to ensure free flow through the channels. The piers and abutments should be examined for excessive scour and make good the same if required. The upstream and downstream areas should be cleared of all CD works.

In case of Causeway following aspect shall be taken into consideration:

- Dislocation of stones in stone set pavements, scouring of filler material due to eddy currents.
- Floating debris block the vents. In case of large amount of floating material, debris arrestor shall be provided in upstream side.
- Damage to guide stones, information board shall be inspected and replaced accordingly.

Schedule of Inspection shall be drawn up for checking cracks, settlements and unusual backpressures. It must be ensured that all the rectification shall be undertaken as and when required. Following

are broadly the items to be checked:

- Settlement of piers/abutments & settlement of approach slabs have to be checked;
- Cracks in C-D structures or RCC slabs;
- Drainage from shoulders to be ensured;
- Ditches & drains to be kept clean of debris or vegetation growth; and
- Repairs to parapet of culverts whenever required are to be undertaken.

GUIDELINE-11: CONSTRUCTION PLANTS & EQUIPMENT MANAGEMENT

1. GENERAL

During execution of the project, construction equipments, machinery and plants are likely to cause adverse impact on the environment. The impact can be due to the emissions, dust, noise and oil spills that concern the safety and health of the workers, surrounding settlements and environment as a whole. This guideline describes the activities during the project stages where pollution control measures are required.

2. PROJECT PLANNING AND DESIGN STAGE

Selection criteria for setting up a plant area and parking lot for equipments and vehicles shall be done as per siting criteria for construction camp specified in Guideline on “Construction and Labour Camps”.

3. PRE-CONSTRUCTION STAGE

The Contractor must educate the workers to undertake safety precaution while working at the plant / site as well as around heavy equipments. Before setting up the crusher, hot-mix plant and generator, the Contractor shall acquire “No Objection Certificate (NOC)” from the Gujarat State Pollution Control Board for the same. The Contractor shall ensure all vehicles must possess Pollution under Control (PUC) Certificate, which and shall be renewed regularly. The Contractor must ensure that all machinery, equipments, and vehicles shall comply with the existing Central Pollution Control Board (CPCB) noise and emission norms. The Engineer - Incharge must ensure that the Contractor shall submit a copy of the NOC and PUC Certificates before the start of work. The Contractor shall design the service road with protection measures as black topping at vulnerable points as in low lying areas.

4. CONSTRUCTION STAGE

The Contractor shall undertake measures as per **Table 11-1** to minimize -the dust generation, emissions, noise, oil spills, residual waste and accidents at the plant site as well as during transportation of material to construction site.

Table 11-1: Measures at Plant Site

Concern	Causes	Measures
Dust Generation	Vehicle Movement	<ul style="list-style-type: none"> •Water sprinkling •Fine Materials shall be Transported in Bags or Covered by Tarpaulin during Transportation •Tail board shall be properly closed and sealed to be spill proof
	Crushers	<ul style="list-style-type: none"> • Regular Water Sprinkling to keep the dust below visibility level
	Concrete-Mix Plant	<ul style="list-style-type: none"> • Educate the workers to follow/adopt good engineering practices while material handling
Emissions	Hot-Mix Plant	<ul style="list-style-type: none"> •Site Selection as per Clause 6.5.2, Section 6.5, IRC’s Manual for Construction & Supervision of Bitumen Work •Regular maintenance of Dust Collector as per manufacture’s recommendations
	Vehicles	<ul style="list-style-type: none"> • Regular maintenance as per manufacture’s recommendation
	Generators	<ul style="list-style-type: none"> • Exhaust vent of long length and emission to confirm to PCB norms.
	Heavy Load Vehicles	<ul style="list-style-type: none"> • Exhaust silencer, Regular maintenance as per manufacture schedule
	Crushers	<ul style="list-style-type: none"> • Siting as per guideline, “Construction and Labour Camps”
Noise	Generators	<ul style="list-style-type: none"> • All generators should have mandatorily acoustic enclosures and confirms to PCB norms.
Oil Spills	Storage and Handling	<ul style="list-style-type: none"> • Good practice, guideline, “Waste Management and Debris Disposal”
Residual waste	Dust Collector and Pits	<ul style="list-style-type: none"> • Guideline , “Waste Management and Debris Disposal”
Concrete waste	Concrete-Mix plant	<ul style="list-style-type: none"> • Guideline, “Waste Management and Debris Disposal”
Bitumen and bitumen mix	Hot-mix Plant	<ul style="list-style-type: none"> • Guideline, “Waste Management and Debris Disposal”
Stone chips	Crushers	<ul style="list-style-type: none"> • Guideline, “Waste Management and Debris Disposal”
Safety	Trajectory of Equipments	<ul style="list-style-type: none"> • No worker shall be present in the vicinity of the equipments
	Movable Parts	<ul style="list-style-type: none"> • Caution Sign, awareness among workers

Concern	Causes	Measures
	of Equipments	
	Plant Area / Site	• Caution Sign, Safety Equipments
	Accidents / Health	• First Aid Box, Periodic Medical Checkup
	Break down of vehicles	• Arrangement for towing and bringing it to the workshop

During site clearance, all cut and grubbed materials shall be kept at a secured location so that it does not raise any safety concerns. During excavation, water sprinkling shall be done to minimize dust generation. Frequent water sprinkling shall be done on the haul roads to minimize dust generation. In case of loose soils, compaction shall be done prior to water sprinkling. Cautionary and inforamatory sign shall be provided at all locations specifying the type of operation in progress. The contractor must ensure that there is minimum generation of dust and waste while unloading the materials from trucks. The construction waste generated shall be disposed as per Guideline on, "Waste Management and Debris Disposal". The equipments, which are required to move forward and backward, shall be equipped with alarm for backward movement. It shall be ensured that the workers shall remain away from the working areas at such times. Also, equipments at construction camp should be barricaded and kept away from residential quarters of workers.

The Engineer - Incharge shall carry out periodic inspections to ensure that all the pollution control systems are appropriately installed and comply with existing emission and noise norms.

5. POST-CONSTRUCTION STAGE

The Engineer - Incharge shall ensure that all the haul roads are restored to their original state. In case any inner village road is damaged while transporting the procured material; the contractor shall restore the road to its original condition. The Engineer - Incharge must ensure that the decommissioning of plant shall be done in environmentally sound fashion and the area to bring its original state.

Designated area refers to paved surfaces and barren parcels of land, with adequate drainage and disposal system. It must be ensured that these are away from agriculture land, water body and other sensitive areas.

Safety Measures During Bitumen Construction Work...

- The Contractor shall ensure that bitumen storing, handling as well as mixing shall be done at hot-mix plant or designated areas¹ to prevent contamination of soil and ground water.
- Skilled labour shall be used while hand placing the pre-mixed bitumen material. The hand placing of pre-mixed bituminous material shall be done only in following circumstances:
 - For laying profile corrective courses of irregular shape and varying thickness
 - In confined spaces where it is impracticable for a paver to operate and
 - For filling potholes
- The Contractor shall provide safety equipments i.e. gumboots and gloves to the workers while handling bitumen.
- While applying Tack Coat, spraying of bitumen shall be done in the wind direction. The labour shall wear jacket while spraying the bitumen.
- All the bituminous work shall be done as per IRC's Manual for Construction and Supervision of Bituminous Works.

GUIDELINE-12: LABOUR AND WORKER'S HEALTH AND SAFETY

1. INTRODUCTION

The safety and health concerns of the workers and the community are impacted due to the hazards created during the construction of road. **Box: 1** gives the safety concerns during construction. This Guideline describes the hazards and measures that need to be taken to mitigate the impacts.

2. PROJECT PLANNING AND DESIGN STAGE

To address health and safety concerns, the DPR shall contain selection criteria for setting up:

- Construction Camps (as per guideline);
- Borrow Areas (as per guideline); and
- In case of opening new quarry areas (as per guideline).

To address the safety concerns to road user during operational phase, the DPR shall contain the following:

- Selection and location of regulatory as well as informatory signs as per IRC: 67-2001, depending upon the geometry of the road.

Box 1: Safety Concerns during Construction

Community due to:

- Improper scheduling of construction activities especially near the settlements and sensitive areas;
- Parking of equipments and vehicles at the end of the day likely to cause accidents to the general public especially during night hours;
- Transportation of uncovered loose material or spillage of material increases the chances of accidents to road users and surrounding settlements.

Workers due to:

- Improper handling of materials like bitumen, oil and other flammable material at construction sites, likely to cause safety concerns to the workers;
- Lack of safety measures such as alarm, awareness and safety equipment result in accidents, especially working with or around heavy machinery / equipments.

PRE-CONSTRUCTION STAGE

In order to incorporate public health and safety concerns, the Engineer - Incharge and the Contractor shall disseminate the following information to the community:

- Location of construction camps, borrow areas and new quarry areas;
- Extent of work;
- Time of construction;
- Diversions, if any;
- Precaution measures in sensitive areas;
- Involvement of local labours in the road construction;
- Health issues - water stagnation, exposure to dust, communicable disease; and
- Mechanism for grievances.

The information dissemination could be through the local newspaper, billboards, panchayats meetings, etc. The Contractor must educate the workers to undertake the health and safety precautions. The contractor shall educate the workers regarding:

Health Concerns are adversely impacted.....

Public due to:

- Unhygienic conditions due to water logging (improper drainage of waste water), either by improper decommissioning of Construction Camps and parking lots, or improper disposal of construction wastes, leading to the breeding of vectors that are likely to impact the health of the general public
- Interaction between workers and host community is likely to increase the risk of spread of communicable diseases.

Workers due to:

- Low quality drinking water as well as inappropriate storage of drinking water likely to cause water borne diseases among workers.
- Absence of proper sanitary facility likely to act as a breeding ground for vectors raising health concerns among workers.

- Awareness on HIV/AIDS awareness and usage of safety measures such as condoms;
- Awareness on hygienic sanitary practices;
- Personal safety measures and location of safety devices;
- Interaction with the host community;
- Protection of environment with respect to:
 - Trampling of vegetation and cutting of trees for cooking;
 - Restriction of activities in forest areas and also on hunting;
 - Water bodies protection;
 - Storage and handling of materials;
 - Disposal of construction waste.

3. CONSTRUCTION STAGE

During the progress of work, following are the safety requirements that need to be undertaken by the contractor at the construction site:

- Personal Protective Equipments (PPE) for the workers. **Table 12-1** gives the safety gear to be used by the workers during each of the construction activities.
- All measures as per bidding document shall be strictly followed.
- Additional provisions need to be undertaken for safety at site:
 - Adequate lighting arrangement;
 - Adequate drainage system to avoid any stagnation of water;
 - Lined surface with slope 1:40 (V:H) and provision of lined pit at the bottom, at the storage and handling area of bitumen and oil, as well as at the location of generator (grease trap); and
 - Facilities for administering first aid.

Table 12-1: Worker Safety Measures

FIRST AID FACILITIES

- First Aid Kit, distinctly marked with Red Cross on white back ground and shall contain minimum of following:
 - 6 small-sterilized dressings
 - 3 medium and large sterilized dressings
 - 1 (30 ml) bottles containing 2 % alcoholic solution of iodine
 - 1(30 ml) bottle containing salvolatile
 - 1 snakebite lancet
 - 1 pair sterilized scissors
 - 1 copy of first-aid leaflet issued by the Director General, Factory Service & Labour Institute, Government of India
 - 100 tablets of aspirin
 - Ointment for burns
 - A suitable surgical antiseptic solution
- Adequate arrangement shall be made for immediate recoupment of the equipments, whenever necessary.
- A trained personnel incharge of first aid treatment to be readily available during working hours at construction site
- Suitable transport to the nearest approachable hospital should be made available.
- Tetanus injection must be made compulsory for all workers every 6 months.

Sl. no.	Activity	Safety Requirement
1.	Setting out and levelling	<ul style="list-style-type: none"> • Luminous jackets; • Helmets; • Boots for protection against insect bite; and Dust Mask
2.	Tree cutting	<ul style="list-style-type: none"> • Helmet Boots • Luminous safety jackets
3.	Reinforced yard/ carpentry/ reinforcement cutting/ bending work.	<ul style="list-style-type: none"> • Hand gloves
4.	Shuttering work	<ul style="list-style-type: none"> • Goggles Hand gloves
5.	Plant and Machinery	<ul style="list-style-type: none"> • Hand gloves • Boots • Helmets • Dust Mask
6.	Material handling	<ul style="list-style-type: none"> • Hand gloves • Dust mask
7.	Batching plant	<ul style="list-style-type: none"> • Goggles • Hand gloves • Dust mask
8.	Weeding	<ul style="list-style-type: none"> • Goggles
9.	Binding reinforcement	<ul style="list-style-type: none"> • Safety belt • Boots

Sl. no.	Activity	Safety Requirement
10.	Manual concrete laying	<ul style="list-style-type: none"> • Gum boots • Hand gloves • Helmet
11.	Piling	<ul style="list-style-type: none"> • Helmet • Hand gloves, gumboots.

The following measures need to be adopted by the contractor to address public safety concerns:

- The Contractor shall schedule the construction activities taking into consideration factors such as:
 - Sowing of crops;
 - Harvesting;
 - Local hindrances such as festivals etc.; and
 - Availability of labour during particular periods.
- All the cautionary signs as per IRC: 67-2001 and traffic control devices (such as barricades, etc) shall be placed as soon as construction activity get started and shall remain in place till the activities get completed.
- Following case specific measures need to be followed during the progress of the activity:
 - In case of blasting, the Contractor must follow The Explosives Rules, 1983.
 - In case of construction activity adjoining the water bodies, measures shall be taken as per measures suggested in Guideline on “Water Body”.
 - If construction of road is within the settlement, the contractor must ensure that there shall not be any unauthorized parking as well as storage of material, adjacent to road.
 - Approved chemicals should be sprayed to prevent breeding of mosquitoes and other disease-causing organisms, at all the water logging areas

The Engineer - Incharge shall carry out periodic inspections in order to ensure that all the measures are being undertaken as per the guideline.

4. POST-CONSTRUCTION STAGE

During this stage a major concern is on road user safety. Following are the measures that need to be undertaken by the Engineer -Incharge to ensure safer roads:

- Inspection and maintenance of installed regulatory and informatory signs.
- Ensure that the location of signage does not obstruct the visibility
- In case of hill roads, maintenance of parapet wall as well as of overtaking zones.

The Engineer - Incharge must ensure that during the maintenance operation of road, road materials are stored at a location such that they shall not create any risk to road users.

The construction site shall be cleaned of all debris, scrap materials and machinery on completion of construction for the safety of public and road users, as per the measures given in Guideline on “Construction and labour Camp” and “Waste Management and Debris Disposal.”

GUIDELINE-13: CULTURAL PROPERTIES

1. INTRODUCTION

The cultural properties located close to the road are likely to be impacted by the road construction. Most of the properties are avoided in general during finalization of alignment. This Guideline discusses the mitigation measures for cultural properties.

2. PROJECT PLANNING AND DESIGN STAGE

Measures for mitigation of impacts on cultural properties during project preparation shall be as per the following steps:

- Identification of locally significant cultural properties should be done;
- Assessment of likely impacts on each cultural property due to project implementation;
- The extent of impact on the identified culture property should be assessed and possible measures for avoidance should be devised based on the site investigation. In case impact is not avoidable, identification of alternative routes or possibility of relocation of the culture property shall be assessed in consultation with the local public, based on the economic feasibility.

In case of relocation, relocated site should be suggested by the local people and the size of relocated structure should at least be equal to the original structure. A written consent letter is to be obtained from the community regarding the relocation site of the cultural property in the form of resolution on the letter pad of the sarpanch/gram panchayat or with the signatures of community members.

A detailed design of the relocated structure and its site plan along with the necessary BoQ are to be presented DPR. The relocation and other avoidance measures should be carried out before the start of the road work

It must be ensured by the Engineer - Incharge that the BoQ and rates are incorporated into the contract document.

3. CONSTRUCTION STAGE

Major impacts on the properties during this stage are mainly due to movement of construction machinery as well as due to construction activity in the vicinity of the cultural property. Following are precautionary measures that need to be undertaken by the contractor while working near these structures:

- Restrict movement of heavy machinery near the structure
- Avoid disposal or tipping of earth near the structure
- Access to these properties shall be kept clear from dirt and grit

During earth excavation, if any property is unearthed and seems to be culturally significant or likely to have archeological significance, the same shall be intimated to the Engineer. Work shall be suspended until further orders from Engineer - Incharge. The State Archeological Department shall be intimated of the chance find and the Engineer shall carry out a joint inspection with the department. Actions as appropriate shall be intimated to the Contractor along with the probable date for resuming the work.

The Engineer - Incharge must ensure that the contractor implements the precautionary measures as suggested. Also, the Engineer - Incharge must conduct monitoring for the cultural property.

Information to be collected...
• Location
• Direction (North/ South/East/West) With Respect to Road
• Distance of the structure from existing centerline of the road
• Type of Property eg: temple/mosque/shrine/dargah etc
• Plan of the structure
• Importance of the structure – historical/social/archeological
• Ownership of the property
• Probable loss to the property
• Specific periods/durations in which large congregations as festivals/mela take place causing hindrance to vehicular movement
• Choice of community, issue of relocation

GUIDELINE-14: TREE CUTTING AND AFFORESTATION

This Guideline discusses the issue of tree cutting and afforestation. Loss of trees creates adverse environmental impacts. In order to mitigate these impacts, suitable measures have been suggested as part of this Guideline. These measures have been given for each of the stages of the road construction activities.

1. PROJECT PLANNING AND DESIGN STAGE

During alignment finalisation, due consideration shall be given to minimise the loss of existing tree cover, encroachment of forest areas / protected areas etc as specified in guideline on, “Site preparation”. Tree felling, if unavoidable, shall be done only after compensatory plantation of at least three saplings for every tree cut is done.

The plantation/afforestation would be carried out by the forest department. It should be ensured that plantation is carried out only in areas where water can be made available during dry seasons and the plant can be protected during the initial stages of their growth. The species shall be identified giving due importance to local flora (suggested in **Table 14-1**). It is recommended to plant mixed species in case of both avenue or cluster plantation.

The plantation strategy shall suggest the planting of fruit bearing trees and other suitable trees. Development of cluster plantations will be encouraged in the community lands, at locations desired by the community. The choice of species will be based on the preferences of the community. The Engineer - Incharge shall oversee the plantation to check the following:

- Whether trees are obstructing line of sight at junctions;
- Whether trees are at the inside of the junctions;
- Whether trees are within 5 mts of the proposed centerline.

2. POST-CONSTRUCTION STAGE

The maintenance of the saplings (including activities such as weeding, watering, planting of replacement saplings, etc application of manure etc) shall be the responsibility of the forest department. The Engineer - Incharge shall ensure the following:

- Shoulder of roads to be kept clear of weeds/undesirable undergrowth; and
- Branches of trees do not obstruct clear view of the informative and caution signs.

Table 14-1: Endemic Species of Gujarat

Sl.no	Tree Species Endemic species)	Sl.no	Tree Species Endemic species)
1	<i>Tectonagrandis</i>	9	<i>Brideliasquamosa</i>
2	<i>Anogeissuspendula</i>	10	<i>Emblicaofficinallis</i>
3	<i>Boswelliaserratta</i>	11	<i>Buteamonosperma</i>
4	<i>Acacia nilotica</i>	12	<i>Diospyrosmelanoxylon</i>
5	<i>Euphorbia caducifolia</i>	13	<i>Anogeissuslatifolia</i>
6	<i>Flacourtiaindica</i>	14	<i>Lanneacoromandelica</i>
7	<i>Helicteresisora</i>	15	<i>Sterculiaurens</i>
8	<i>Holarrhenaantidysentrica</i>	16	<i>Mitragynaparviflora</i>

GUIDELINE-15: FORESTS AND OTHER NATURAL HABITATS

1. INTRODUCTION

This guideline envisages measures to be undertaken during blacktopping / widening of road sections passing through natural habitats. These measures shall be undertaken in addition to the measures laid down in the other Guidelines.

Conservation of natural habitats is essential for long-term sustainable development. A precautionary approach to natural resource management to ensure opportunities for environmentally sustainable development has been adopted for the project.

Natural Habitats means...
<ul style="list-style-type: none"> National Park Reserve Forest Sanctuaries Notified Wetlands Fisheries and Aquatic Habitats

2. PROJECT PLANNING AND DESIGN

To minimize the adverse impact on the ecology of the natural habitats, selection of alignment should be as per guideline. An officer of at least the rank of a forest ranger shall be deputed for detailed inventory of ecological features along the road. The nature and type of impact on natural habitats due to road construction shall be identified. Magnitude of the impact to the extent feasible on the ecological features shall also be assessed.

Ecological Features...	Adverse Impacts...
<ul style="list-style-type: none"> Area of natural habitat; Type and number of endangered species of flora and fauna; Stream and water bodies; Breeding ground and seasons; Migration season of bird species; and Animal crossing. 	<ul style="list-style-type: none"> Diversion of forest land; Cutting of trees; Trampling of vegetation; Contamination of water due to the usage of water from the source within the natural habitat; Loss of breeding grounds; and Interruption to animal crossings during the construction.

Impacts identified on the natural habitats shall be minimized to the extent required. Minimization shall be through precautionary measures or through appropriate mitigation measures. Following are the measures should be undertaken along the road passing through natural habitats:

- Constricting the road width to 6.0 m and embankment height to 0.5 m to minimize the extent of diversion of forest land and cutting of trees
- Drainage Structures shall be designed strictly in accordance with guideline on “Drainage”.
- Rumble strips shall be provided at every kilometer along the length of the natural habitat and invariably at the start and end of the natural habitat
- Signage (viz. speed limit, animal crossing, switch of headlight etc) shall be provided as per IRC: 67-2001 Code of Practice for road sign (first revision)

In addition to the above measures, specific impacts identified on site shall be mitigated as per the recommendation of the forest department / officer in charge of the identified natural habitat.

In case proposed alignment falls within the catchments of a water body or a stream, a flush causeway shall be constructed without impacting the drainage system. The length of the causeway shall be as per the existing water spread. The causeway shall be strictly in compliance with IRC:SP-20:2002. In no circumstances a water body within the natural habitat shall be cut across or filled for the purpose of laying the road.

3. PRE-CONSTRUCTION STAGE

No Construction Camps, Stockyards, Concrete Batching or Hot Mix Plants shall be located within the natural habitat or within 500m from its boundary.

Contractor in consultation with forest ranger or any other concerned authority shall prepare a schedule of construction within the natural habitat. Due consideration shall be given to the time of migration, time of crossing, breeding habits and any other special phenomena taking place in the area for the concerned flora or fauna.

4. CONSTRUCTION STAGE

Procurement of any kind of construction material (as quarry or borrow material) from within the natural habitat shall be strictly prohibited. No water resources within the natural habitat shall be tapped for road construction. Use of mechanized equipment shall be kept minimum within the natural habitat. Contractor must ensure that there will be no parking of vehicles machine and equipment within the natural habitat. Disposal of construction waste within the natural habitat shall be strictly prohibited and as far as possible reuse shall be undertaken as per **Table -1** type of waste of guideline, "Waste Management and Debris Disposal".

5. POST CONSTRUCTION STAGE

The road passing through the natural habitat shall be declared as a silence zone. Compensatory tree plantation within the available Right of Way shall be done in accordance with guideline, on "Tree Cutting and Afforestation". The Engineer - Incharge must ensure maintenance of drainage structure shall be undertaken as per guideline, "Drainage"

GUIDELINE-16: AIR AND NOISE POLLUTION

1. INTRODUCTION

This guideline deals with the mitigation of adverse impacts due to air and noise pollution. Both of these have been discussed in the subsequent sections respectively.

2. AIR POLLUTION

The types of air pollution due to construction activities might include generation of dust, emission from hot mix plants and batching plants, odour from construction labour camps, emission from construction machinery/vehicles etc. The measures for mitigation of impacts from each of these are given below.

Generation of Dust

- All vehicles delivering materials to the site shall be covered to avoid spillage of materials.
- The Contractor shall take every precaution to reduce the level of dust emission from the hot mix plants and the batching plants up to the satisfaction of the Engineer in accordance with the relevant emission norms.
- All existing highways and roads used by vehicles of the contractor, or any of his sub-contractor or supplies of materials or plant and similarly roads which are part of the works shall be kept clean and clear of all dust/mud or other extraneous materials dropped by such vehicles or their tyres.
- Spillage shall be cleared immediately by manual sweeping and removal of debris or if so directed by the Engineer, by mechanical sweeping and clearing equipment, and all dust, mud and other debris shall be removed completely. Additionally, if so directed by the Engineer, the road surfaces shall be hosed or watered using necessary equipments.
- Plants, machinery and equipment shall be so handled (including dismantling) so as to minimize generation dust.
- All earthwork shall be protected in a manner acceptable to the Engineer to minimise generation of dust.
- The hot mix plant is sited at least 1000m from the nearest habitation. The hot mix plants shall be fitted with dust extraction units in order that the exhausts comply with the requirements of the relevant current emission control legislation.
- Generation of dust should be suppressed during unloading of construction material and also during storage of the construction material.

Emission from Hot-Mix Plants and Batching Plants

- Hot mix plants and batching plants shall be located sufficiently away from habitation, agricultural operations or industrial establishments. Where possible such plants will be located at least 1000m away from the nearest habitation.
- The exhaust gases shall comply with the requirements of the relevant current emission control legislation. All operations at plants shall be undertaken in accordance with all current rules and regulations protecting the environment.

Odour from Construction Labour camps

- Construction labourers camp shall be located at least 500 m away from the nearest habitation.
- The waste disposal and sewerage system for the camp shall be properly designed, built and operated so that no odour is generated. Compliance with the Factory Act, the construction workers (regulation of employment and conditions of service) Act, 1996 and all other relevant legislation shall be strictly adhered to.

Emission from Construction Vehicles, Equipment and Machinery

- The discharge standards promulgated under the Environment Protection Act, 1986 shall be strictly adhered to. All vehicles, equipment and machinery used for construction shall conform to the relevant Indian Standard (IS) norms.
- All vehicles, equipment and machinery used for construction shall be regularly maintained to ensure that pollution emission levels comply with the relevant requirements of SPCB & the Engineer.

Pollution from Crusher

- All crushers used in construction shall conform to relevant dust emissions control as legislated. Clearance for siting shall be obtained from the SPCB. Alternatively, only crushers already licensed by the SPCB shall be used.
- Dust screening vegetation will be planted on the edge of RoW for all existing roadside crushers.
- If crusher owned by contractor, the suspended particulate matter contribution value at a distance of 40m from a controlled isolated as well as from a unit located in a cluster should be less than $600 \mu\text{g}/\text{Nm}^3$. The monitoring is to be conducted at least twice a month for all the 12 months in a year during the crushing operation for the project.

3. NOISE POLLUTION

Noise from Vehicles, Plants and Equipment

- The plants and equipment used in construction (including the aggregate crushing plant) shall strictly conform to the Gol noise standards.
- All vehicles and equipment used in construction shall be fitted with exhaust silences. During routine servicing operations, the effectiveness of exhaust silencers shall be checked and if found to be defective shall be replaced. Notwithstanding any other conditions of contract, noise level from any item of plant(s) must comply with the relevant legislation for levels of sound emission. Non-compliant plant shall be removed from site.
- Noise limits for construction equipment used in this project (measured at one meter from the edge of the equipment in free field) such as compactors, rollers, front loaders, concrete mixers, cranes (moveable), vibrators and saws shall not exceed 75 dB(A), as specified in the Environment (Protection) Rules, 1986.
- Maintenance of vehicles, equipment and machinery shall be regular and proper, to the satisfaction of the Engineer, to keep noise from these at a minimum.
- In construction sites within 150 m of the nearest habitation, noisy construction work such as crushing, concrete mixing and batching, mechanical compaction, etc., will be stopped between 2200 hours to 0600 hours. In silence zone (areas up to 100 m around such premises as hospitals, educational institutional and courts) no hot-mix, batching or aggregate crushing plant will be allowed. No construction shall take place within 100m around hospitals between 21.00 hours to 06.00 hours.
- Workers in vicinity of strong noise, and workers working with or in crushing, compaction, batching or concrete mixing operations shall wear earplugs.

Noise from Blasting (or) Pre splitting Operations.

- Blasting shall be carried out only with permission of the Engineer. All the statutory laws, regulators, rules, etc., pertaining to acquisition, transport, storage, handling and use of explosives shall be strictly followed.
- Blasting shall be carried out during fixed hours (preferably during mid-day), as permitted by the Engineer. The timing should be made known to all the people within 500m (200m for pre-splitting) from the blasting site in all directions. People, except those who actually light the fuse shall be excluded from the area of 200m (50m for pre-splitting) from the blasting site in all directions at least 10m minutes before the blasting.

Appendix - 5: Bill of Quantities (BoQ)

Sr. No.	Description	Unit	Phase	Estimated Quantity	Unit Rate (Rs.)	Amount (Rs.)
10.00	Implementation of Environmental Management Action Plan to be executed under Civil Works Contract					
10.10	Periodic air quality monitoring during construction stage at construction camp sites, bitumen hot mix plants, crusher plants (if specifically established for Project), at major settlement areas along project road. The parameters to be monitored are SPM, RPM, SO ₂ , NO _x and CO, Lead. Each monitoring schedule shall be over a duration of 24 hours (in 8 hour shifts) for three seasons per year. (as per the Environmental monitoring plan referred in the EMP)	Nr	Construction Phase	36.00	7500.00	2,70,000.00
			Operation Phase	18.00	7500.00	1,35,000.00
10.12	Water quality monitoring during construction phase at locations . The sampling shall be carried out for three seasons per year and cover all parameters as per IS10500 including heavy metals . (as per the Environmental monitoring plan referred in the EMP).	Nr	Construction Phase	24.00	6000.00	1,44,000.00
10.13	Noise quality monitoring at specified silent receptors along Project Road, at construction camp sites, bitumen hot mix plants, crusher plants(if specifically established for Project), and at major settlement areas along project road. – Each monitoring schedule shall be over a duration of 24 hours for three seasons per year. (as per the Environmental monitoring plan referred in the EMP)The monitoring shall be carried out in accordance with CPCB norms at locations given.	Nr	Construction Phase	36.00	3000.00	1,08,000.00
			Operation Phase	18.00	3000.00	54,000.00
10.14	Soil quality monitoring at construction camp sites, work shop areas, oil/lubricant handling areas, bitumen hot mix plants, at all parking lay byes, vehicle servicing stations along Project Road. Parameters shall include N, P, oil and grease, heavy metals, C/N ratio, pH, organic matter to be monitored for three seasons per year.(as per the Environmental monitoring plan referred in the EMP)	Nr	Construction Phase	8.00	6000.00	48,000.00
10.18	Enhancement Measures of Cultural Properties					
	Hanuman Temple (32+800)					1,33,682.00
	Providing and laying interlocking paver blocks of high density 80 mm thick M-50 grade in bus-bays, truck layby and other locations as shown in the drawing, close jointed over bed of 50mm thick river sand to a tight pattern, laid to proper line and level including bedding down the completed surface with a plate vibrator or by firmly topping level with mallet and a large flat piece of timber, finishing by brushing clean dry sand over the surface to fill all the joints thoroughly and as per Additional Technical Specification A 15 or as directed by the Engineer.	SQ.M.		50.00	479.00	23,950.00
	Chain Fencing (criss cross 50mm X 50mm) with intermediate stone posts at a distance of 2M c/c upto a height of 1.3 M.	R.M.		41.00	1662.57	68,165.24

Sr. No.	Description	Unit	Phase	Estimated Quantity	Unit Rate (Rs.)	Amount (Rs.)
	Supplying, fitting and fixing double leaf heavy duty iron gate (4M Wide), frame made from 50mm x 6mm M.S. flat iron with another horizontal flat at the middle, 20mm dia M.S bars at 200mm apart from bottom flat to top flat and 20 mm dia M.S. bars at 200mm apart from bottom flat to middle flat including drilling, welding etc. complete. All vertical bars are to be protruded at least 100mm above the middle and top flat is to be flattened and pointed as directed. Necessary locking arrangement on both faces, arrangement for temporary closing the gate and 2 nos.(minimum) strong iron hinges of M.S bars and flat of same sizes on each leaf to be embeded in C.C brick pillars as necessary including a red oxide painting to all iron works as directed and specified.	Number		1.00	7302.46	7,302.46
	Concrete Shoe Rack (as/spec.)	Number		1.00	30073.72	30,073.72
	Planting of trees and their maintenance for one year (Planting of Ornamental Trees) in 0.60 m dia holes, 1 m deep dug in the ground, mixing the soil with decayed farm yard/sludge manure, planting the saplings, backfilling the trench, watering, fixing the tree guard and maintenance tree for 1 year)	Number		5.00	587.37	2,936.87
	Half brick circular tree guard in 2nd class brick, internal diameter 0.9 metres, height 0.45 metres, above ground and 0.20 metre below ground. (bottom 2 courses laid dry and top thress courses in cement mortar 1:6 (1 cement and 6 sand) and the intermediate courses being dry honey comb masonry)	Number		5.00	250.63	1,253.17
10.19	HIV/ AIDS Prevention measures					
	IEC materials - printing, publishing			3000.00	24.00	72,000.00
	Healthcare clinic			30000.00	8.00	2,40,000.00
	Condom vending machines			15000.00	3.00	45,000.00
	condom supplies			5000.00	24.00	1,20,000.00
	Testing			1500.00	500.00	7,50,000.00
	Signages and hoardings			15000.00	15.00	2,25,000.00
	Total Implementation of Environmental Management Action Plan to be executed under Civil Works Contract carried to Grand Summary					23,44,682.00
	Grand Total INR. (with 3% contingency)					24,15,023.00