

TYPICAL SECTION
OF R.WALL FOR NAVALI BRIDGE
SH-236, CH-10+475

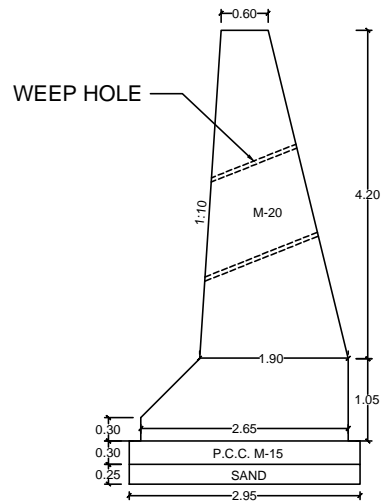

TYPICAL SECTION
OF R.WALL FOR GAGADIO CH-27+490 &
KHARI BRIDGE CH-32+117 SH-236

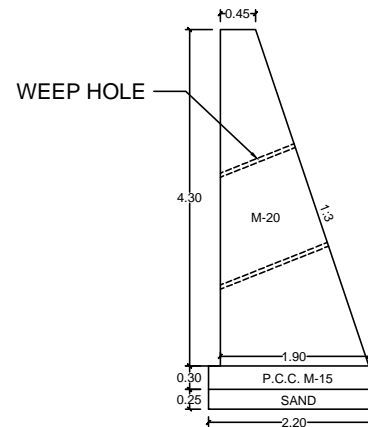

TYPICAL SECTION
OF PROTECTIVE WALL AT
FOLLOWING CHAINAGE SH-236

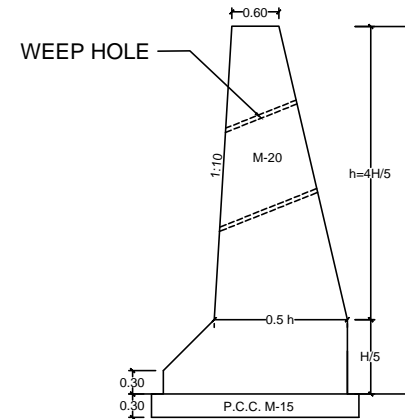

TYPICAL SECTION
OF R.WALL

CHAINAGE	LHS	RHS
40+800 TO 41+000	200	-
41+000 TO 41+300	300	300
41+300 TO 41+700	400	-
43+750 TO 43+800	50	-
44+420 TO 45+350	930	-
45+250 TO 45+550	200	200
45+550 TO 46+350	800	-
46+350 TO 46+500	150	150
46+500 TO 46+775	275	-

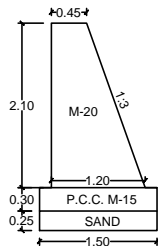

TYPICAL SECTION
OF PROTECTIVE WALL IN SPILL SECTION
BETWEEN CH-13+100 TO 14+500, SH-236

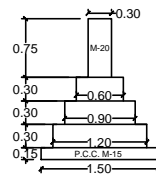

TYPICAL SECTION
OF APROAN CURTAIN WALL CH-28+690,
43+018 SH-236 & CH-12+300 SH-021

TYPICAL SECTION OF RETAINING WALL, PROTECTIVE WALL & CURTAIN WALL

DEPUTY EXECUTIVE ENGINEER
STATE ROAD PROJECT DIVISION
RAJKOT

EXECUTIVE ENGINEER
STATE ROAD PROJECT DIVISION
RAJKOT

SCALE :
NOT TO SCALE

STATE ROAD PROJECT DIVISION
RAJKOT

GOVERNMENT OF GUJARAT
ROADS AND BUILDINGS DEPARTMENT

SAVARKUNDLA - DHASA ROAD SH 021 & 236
ROAD MAINTENANCE PROGRAMME

DATE: PROJECT: DWG No: REV: